

L&R ISO DRY CONTAINER REPAIRING SPARE PARTS CATALOG

2013 Edition



INDUSTRIA LUIS & RICARDO E.I.R.L

L&R Spare Parts Service Business Center

Add: Urbanización El Olivar Mz L Lote 5 / Calle las Moras 109
Callao, Lima - Perú

Tel: (511) 4842320 / (51) 998390284

Fax: (511) 4842320

E-mail: industria_lr@yahoo.es & gerencia@industria-lr.com

Website: www.industria-lr.com



L&R ISO DRY CONTAINER REPAIRING PART CATALOG

2013

NO.	ITEM	PART NO.	SIZE	SPEC	PAGE	
1	Roof Panel	L&R-D01-01	2.0X1045X2356	5 Corr.	1	
		L&R -D01-05	2.0X1045X600	5 Corr. Patch		
		L&R -D01-05-2	2.0X1045X1200	5 Corr.		
		2		L&R -D01-09	2.0X1045X2356	4 Corr.
				L&R -D01-05-3	2.0X1045X600	4 Corr. Patch
				L&R -D01-05-4	2.0X1045X1200	4 Corr.
				L&R -D01-03	2.0X1045X2356	Textainer
		3		L&R -D01-07	2.0X1045X600	Textainer Patch
				L&R -D01-04	2.0X1144X2359	Evergreen
		4		L&R -D01-08	2.0X1144X600	Evergreen Patch
2	Side Panel	L&R -D02-01A	1.6X1116X2400	Standard	5	
		L&R -D02-01B	1.6X1116X2700	Standard		
		L&R -D02-01C	2.0X1116X2400	Standard		
		L&R -D02-01D	2.0X1116X2700	Standard		
		L&R -D02-04A-1	1.6X1016X2400	HanJin		
		L&R -D02-04B-1	1.6X1016X2700	HanJin		
		L&R -D02-05A	2.0X1142X2400	Wide Flange		
		L&R -D02-05B	2.0X1142X2700	Wide Flange		
	Side Panel Patch		L&R -D02-02A	Patch: 1.6X278X150	1 Corr.	
			L&R -D02-02B	Patch: 1.6X278X300	1 Corr.	
			L&R -D02-02C	Patch: 1.6X556X150	2 Corr.	
			L&R -D02-02D	Patch: 1.6X556X300	2 Corr.	
			L&R -D02-02E	Patch: 1.6X556X600	2 Corr.	
			L&R -D02-02F	Patch: 1.6X1116X300	4 Corr.	
			L&R -D02-02G	Patch: 1.6X1116X600	4 Corr.	
L&R -D02-02H	Patch: 1.6X1116X1200	4 Corr.				
3	Front End Panel	L&R -D03-01A	2.0X1024X2400	4 Corr.	7	
		L&R -D03-01B	2.0X1024X2700	4 Corr.		
		L&R -D03-02A	2.0X1024X2400	Evergreen,5 Corr.		
		L&R -D03-02B	2.0X1024X2700	Evergreen,5 Corr.		
	Front End Panel Patch		L&R -D03-03	2.0X256X2700	1 Corr.	
			L&R -D03-04	2.0X546X2700	2 Corr.	
			L&R -D03-05	2.0X796X2700	3 Corr.	
4	Door Panel	L&R -D04-01A	2.0X943X1957	20'&40', 2 Corr.	9	
		L&R -D04-01B	2.0X943X2262	40'HC, 2 Corr.		
		L&R -D04-02A	2.0X943X1957	20'&40', 3 Corr.		
		L&R -D04-02B	2.0X943X2262	40'HC, 3 Corr.		
		L&R -D04-03A	2.0X943X1957	20'&40', 4 Corr.		
		L&R -D04-03B	2.0X943X2262	40'HC, 4 Corr.		

NO.	ITEM	PART NO.	SIZE	SPEC	PAGE
5	Front Corner Post	L&R-D05-01A	6.0X209X225X2400	Standard	10
		L&R-D05-01B	6.0X209X225X2700		
		L&R-D05-02A	6.0X229X245X2400	Wide Flange	
		L&R-D05-02B-1	6.0X229X245X2725		
		L&R-D05-03A	6.0X229X214X2420		
		L&R-D05-03B	6.0X229X214X2743		
		L&R-D05-03C	6.0X229X214X2700		
		L&R-D05-04A	4.5X240.5X220.5X2400		
		L&R-D05-04B	4.5X240.5X220.5X2700		
		L&R-D05-06A	6.0X248X232X2400		
		L&R-D05-06B	6.0X248X232X2700		
		L&R-D05-07A	6.0X246X231X2420		
		L&R-D05-07B	6.0X246X231X2743		
	Front Corner Post with Reinforcement Inside	L&R-D05-05A	6.0X209X225X2420&3.2X207X2420		
	L&R-D05-05B	6.0X209X225X2720&3.2X207X2720			
6	Rear Corner Post, Outer	L&R-D06-01A	6.0X50X40X232X2400	Standard	12
		L&R-D06-01B	6.0X50X40X232X2700		
		L&R-D06-02A	6.0X70X39X230X2400	Wide Flange	
		L&R-D06-02B	6.0X70X39X230X2700		
	Rear Corner Post, Inner	L&R-D06-03A	10X113X40X2353		
		L&R-D06-03B	12X113X40X2353		
		L&R-D06-03C	12X113X40X2657		
	Rear Corner Post	L&R-D06-04A	L&R-D06-01A & L&R-D06-03A		
		L&R-D06-04B	L&R-D06-01A & L&R-D06-03B		
		L&R-D06-04C	L&R-D06-01B & L&R-D06-03C		
L&R-D06-05A		L&R-D06-02A & L&R-D06-03B			
L&R-D06-05B		L&R-D06-02B & L&R-D06-03C			
7	Cross Member	L&R-D07	4.5/4.0XA(D)XBXCXL		13
8	Bottom Side Rail	L&R-D08-01C	4.5X50X162X30X5702	C Type	14
		L&R-D08-02	4.5X50X155X30X5702	Double Z	
9	Top Side Rail	L&R-D09-01A	3.0X60X60X5702	Square Tube	15
		L&R-D09-02A	12X50X5702	Flat Bar	
		L&R-D09-02C	14X50X5702		
	L&R-D09-03	T=4.0 L=2400 "U" Type	Maersk	16	
	L&R-D09-04	T=4.0 L=2400 "W" Type			
10	Door Sill	L&R-D10-01	4.5X158X150X2400		17
		L&R-D10-03	9.0X200X75X70	C-Channel	18
		L&R-D10-04	10.0X300X95X70	V-Channel	
11	Front Bottom Rail	L&R-D11-01	4.5X115X154X2400	Standard	19
12	Top End Rail	L&R-D12-01	3.0X100X26X277X2400	20'	20
		L&R-D12-02	3.0X121X26X194X2400	40'/40'HC	
		L&R-D12-03	4.0X95X26X304.8X2420	Extension Plate	
13	Door Header Upper	L&R-D13-01	3.0X394X2400	20'	21
		L&R-D13-02	3.0X346X2400	40'/40'HC	
	Door Header Lower	L&R-D13-03	4.0X112X113X137X2400		
14	Door Rail	L&R-D14-01	4.0X50X150X50X943		22
15	Floor Spacer	L&R-D15-01	2.3X42X28X25X3000	Galvanized	
16	Angle	L&R-D16	4.5/6.0/4.0XAXBX2400		23

NO.	ITEM	PART NO.	SIZE	SPEC	PAGE
17	Top / Bottom End Rail	L&R-D17-01A	3.0X60X60X2112	Square Tube	24
18	Door Edge Member	L&R-D18-01A	3.2X50X100X2248	20'&40'	
		L&R-D18-01B	3.2X50X100X2552	40'HC	
19	Corner Casting	L&R-D19-01	178X162X118	set	25
		L&R-D19-01-1	178X162X118	BL	
		L&R-D19-01-2	178X162X118	BR	
		L&R-D19-01-3	178X162X118	TL	
		L&R-D19-01-4	178X162X118	TR	
		L&R-D19-02	178X193X118	45' Width	
		L&R-D19-03	247X180X118	45' Standard	
20	Stainless Door Seal	L&R-D20-01A	1.0X23X7X1130		26
		L&R-D20-01B	1.0X23X7X2249	20'&40'	
		L&R-D20-01C	1.0X23X7X2549	40'HC	
	ABS Door Seal	L&R-D20-03A	2.0X32X9X1142		27
		L&R-D20-03B	2.0X32X9X2242	20'&40'	
21	Sealant (310ml)	L&R-D21-01	Neoprene (Grey)	310ml/pcs, 30pcs/pkg	
		L&R-D21-02	Neoprene (Black/White)		
		L&R-D21-03	Butyl (Grey)		
		L&R-D21-04	Butyl (Black)		
		L&R-D21-05	Silicone Sealant (White)		
22	Nail	L&R-D22-01	C6LB-R12-6G	Replace M10X25	
		L&R-D22-02	C6LB-R12-10G	Replace M10X30	
		L&R-D22-03	C6LB-U6-4 (Steel)	For Ventilator	
		L&R-D22-04	C6LB-U6-5 (Aluminum)		
23	Cam LH/RH	L&R-D23-01A	L.H		28
		L&R-D23-01B	R.H		
	Security Cam	L&R-D23-01C	Security Cam R.H.		
		L&R-D23-01D	Security Cam L.H.		
	Cam with Hole RH	L&R-D23-01G	Security Cam R.H.	Maersk	29
	Keeper LH/RH	L&R-D23-02A	L.H	For Corrugated Door	30
		L&R-D23-02B	R.H		
	Keeper LH/RH	L&R-D23-02C	L.H.	For Flat Door	
		L&R-D23-02D	R.H.		
	Security Keeper	L&R-D23-02E	Security Keeper R.H.		31
		L&R-D23-02F	Security Keeper L.H.		
	Keeper with Hole RH	L&R-D23-02G	Security Keeper R.H.	Maersk	
	Bear'g Bracket Outer L	L&R-D23-03			32
Bear'g Bracket Inner L	L&R-D23-04				
Bear'g Bracket Outer S	L&R-D23-05			33	
Bear'g Bracket Inner S	L&R-D23-06				
Handle	L&R-D23-07A		Forging Type	34	
	L&R-D23-07B		Press Type		
	L&R-D23-07C		Without Hole		
	L&R-D23-07E	ET Security Type			
Retainer Catch	L&R-D23-08A		Forging Type	36	
	L&R-D23-08B		Press Type		
	L&R-D23-08C		Without Hole		
Retainer Plate	L&R-D23-09A		Forging Type	37	
	L&R-D23-09B		Press Type		
	L&R-D23-09C		Forging Type		

NO.	ITEM	PART NO.	SIZE	SPEC	PAGE
	Bush	L&R-D23-10			38
	Handle Hub	L&R-D23-11			
	Rivet	L&R-D23-12			
	Anti - Rack Ring	L&R-D23-13			
	ET Handle Hub	L&R-D23-11E	ET Security Type		39
	ET Rivet	L&R-D23-12E	ET Security Type		
	Upper Short Split Bush	L&R-D23-14			40
	Lower Short Split Bush	L&R-D23-15			
	Split Large Bush	L&R-D23-16		Pair	41
	Split Small Bush	L&R-D23-17		Pair	
24	Hinge Blade	L&R-D24-01		Forging Type	42
		L&R-D24-02		Welding Type	
		L&R-D24-03		Welding Type	
		L&R-D24-04	Nylon	Maersk	
	Hinge Pin	L&R-D24-05	L=108mm		43
		L&R-D24-05-1	L=139mm		
		L&R-D24-05-2	L=94mm		
	Hinge Lug	L&R-D24-06	T=9mm		
	Brass Wash	L&R-D24-07			
	Tir Rope	L&R-D24-09	Tir Rope		
	Lock Box	L&R-D24-10	Lock Box		44
	Bracket Gasket	L&R-DGE06	T=1.0		45
		L&R-DGE07040	T=4.0		
		L&R-DGE08040	T=4.0		
25	Ventilator	L&R-D25-01		"S" Type	46
		L&R-D25-02		"M" Type	47
		L&R-D25-03		TAL	48
26	Door Seal	L&R-D26-01A	Container Set, 20'/40'	"JC" Type	49
		L&R-D26-01B	Container Set, 40'HC	"JC" Type	
		L&R-D26-02A	Container Set, 20'/40'	"C" Type	50
		L&R-D26-02B	Container Set, 40'HC	"C" Type	
		L&R-D26-02C	2.50Mtrs / PC	"C" Type	
		L&R-D26-02D	40.00Mtrs / Roll	"C" Type	
		L&R-D26-02E	300mmX300mm	"C" Type	
		L&R-D26-03A	Container Set, 20'/40'	"J" Type	51
		L&R-D26-03B	Container Set, 40'HC	"J" Type	
		L&R-D26-03C	2.50Mtrs / PC	"J" Type	
		L&R-D26-03D	300mmX300mm	"J" Type	
		L&R-D26-03K	1200mmX1200mm	"J" Type	
		27	Door Screw	L&R-D27-01	M10X25
L&R-D27-02	M10X35				
Door Screw Nut	L&R-D27-03		M10		
Door Screw Rubber	L&R-D27-04		M10		
28	Tapping Screw	L&R-D28-01A	M6X45	Cross Groove	53
		L&R-D28-01B	M6X65	Cross Groove	
		L&R-D28-02A	M8X45	Cross Groove	
		L&R-D28-02A-1	M8X45	Club Groove	
		L&R-D28-02B	M8X50	Cross Groove	
		L&R-D28-02B-1	M8X50	Club Groove	
		L&R-D28-02C	M8X65	Cross Groove	
		L&R-D28-02C-1	M8X65	Club Groove	

NO.	ITEM	PART NO.	SIZE	SPEC	PAGE
	Tapping Screw Bit	L&R-D36-01	Double End	Cross Groove	54
	Tapping Screw Bit	L&R-D36-01-1	Simple End	Cross Groove	
	Tapping Screw Bit	L&R-D36-01-2	Simple End	Club Groove	
	Socket	L&R-D36-01-3	M12.5X12.5		
		L&R-D36-01-4	M19X19		
	Redrill Bit	L&R-D36-02			
29	Stainless Blind Rivet	L&R-D29-01	M4.0X8.0		55
		L&R-D29-02	M4.8X14		
		L&R-D29-03	M4.8X16.7		
30	Lashing Ring	L&R-D30-01	8X70		56
		L&R-D30-02	12X140		
		L&R-D30-03	12X64		
		L&R-D30-05	12X58		
		L&R-D30-06	6X34		
31	CSC Plate	L&R-D31-01	0.8X100X200		57
		L&R-D31-02	0.8X200X250		58
		L&R-D31-03	0.8X210X270		59
32	Wooden Floorboard	L&R-D32-01A	28X1160X2400		60
		L&R-D32-01B	28X640X2400		
		L&R-D32-01C	28X1220X2440		
33	Gooseneck Cross Rail	L&R-D33-01A	4.0X75X100X75X2268		61
		L&R-D33-01B	4.0X100X75X2328		
		L&R-D33-01C	6.0X100X150X60X2328		
	Gooseneck Side Rail	L&R-D33-02	6.0X146X65X3305		62
	Gooseneck Bottom Rail	L&R-D33-03	4.5X26X100X26X1029		
	Gooseneck Plate	L&R-D33-04	4.5X150X1160X3307		
34	Tir Wire	L&R-K01			
	Tir Wire Completed with End 20'	L&R-K01-01	L=22M		
	Tir Wire Completed with End 40'	L&R-K01-02	L=33M		
	Cable Seal End	L&R-K01-03			
	Eyelet	L&R-K01-04			
	Hinge Blade, Open Top	L&R-K01-05	Right Side or Left Side		63
	Hinge Pin with Chain, Open Top	L&R-K01-06			64
	Tarpaulin, Raw Cloth	L&R-K02-03	20', 3mX6.5m		
	Tarpaulin, Raw Cloth	L&R-K02-04	40', 3mX12.6m		
	Roof Bow	L&R-K03-01	T=3.0(1.5) L=2260mm		65
Roof Bow	L&R-K03-02	T=3.0(1.5) L=2325mm			
35	Welding Wire	JQ. MG50-6	T=0.8mm, 15Kgs/roll		
	Welding Wire	JQ. MG50-6	T=1.0mm, 20Kgs/roll		
	Stainless Steel Welding Wire	MIG307S1			
36	Decal	Marking-X			
37	Painting		Exterior Painting, Interior Painting, Zinc Rich Painting, Thinner etc.		

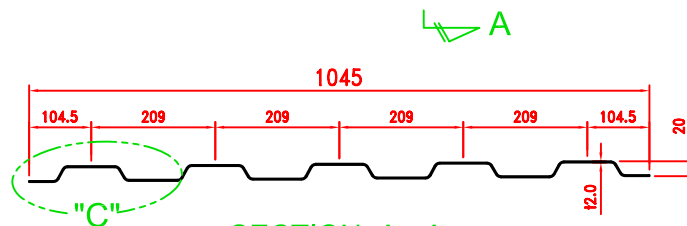
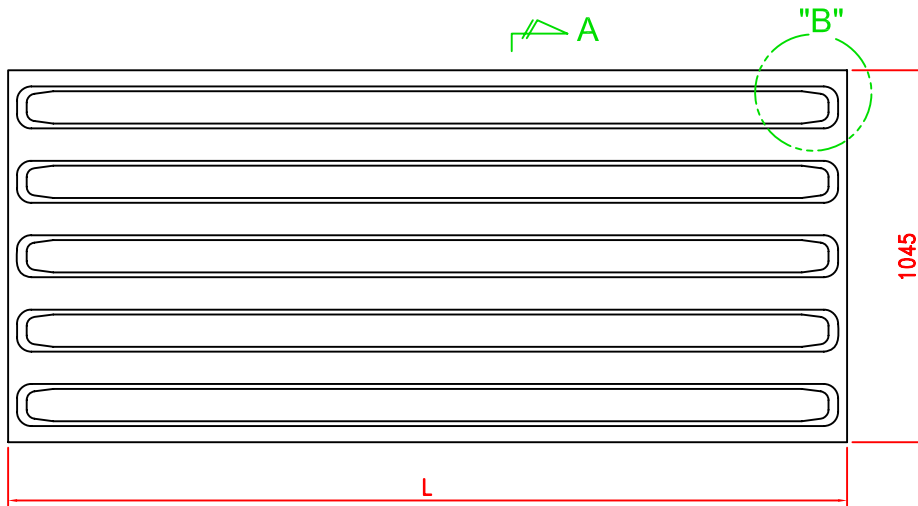

SECTION A - A

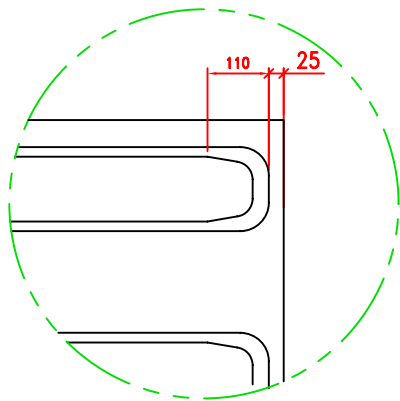

DETAIL "B"

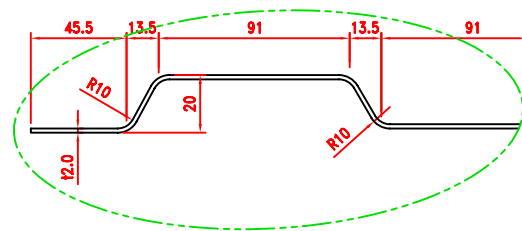

DETAIL "C"

		PART NO.	SPEC
		L&R-D01-01	2.0X1045X2356
		L&R-D01-05	2.0X1045X600
		L&R-D01-05-2	2.0X1045X1200
TITLE	Roof Panel (Patch)	WEIGHT	42.117/11.43/22.865KGS
SPEC	2.0x1045xL	MATERIAL	CORTEN
PART NO.	L&R-D01-01/05/05-2	UNIT	mm
		PAGE NO.	1



L&R

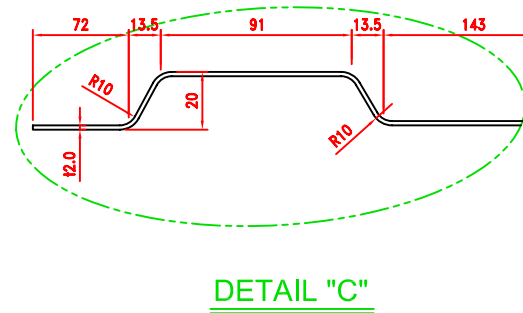
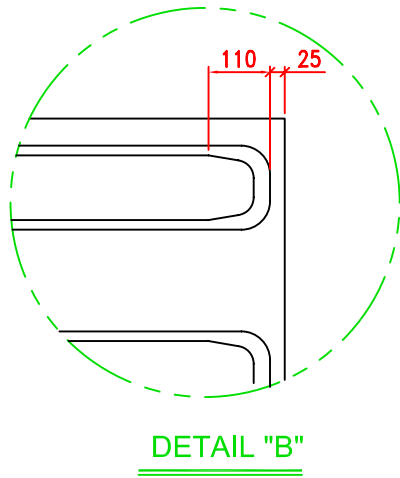
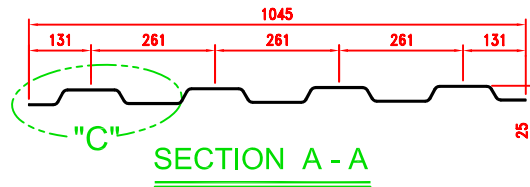
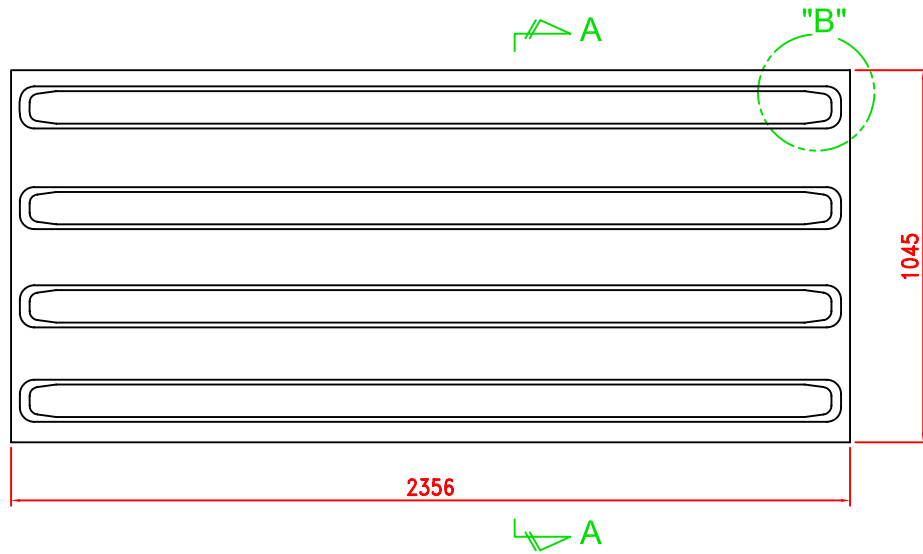

		PART NO.	SPEC
		L&R-D01-09	2.0X1045X2356
		L&R-D01-05-3	2.0X1045X600
		L&R-D01-05-4	2.0X1045X1200
TITLE	Roof Panel (Patch)	WEIGHT	42.22/11.43/22.86KGS
SPEC	2.0x1045xL	MATERIAL	CORTEN
PART NO.	L&R-D01-09/05-3/05-4	UNIT	mm
		PAGE NO.	2

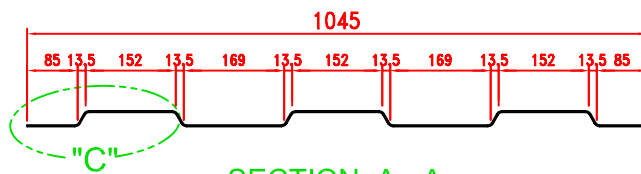
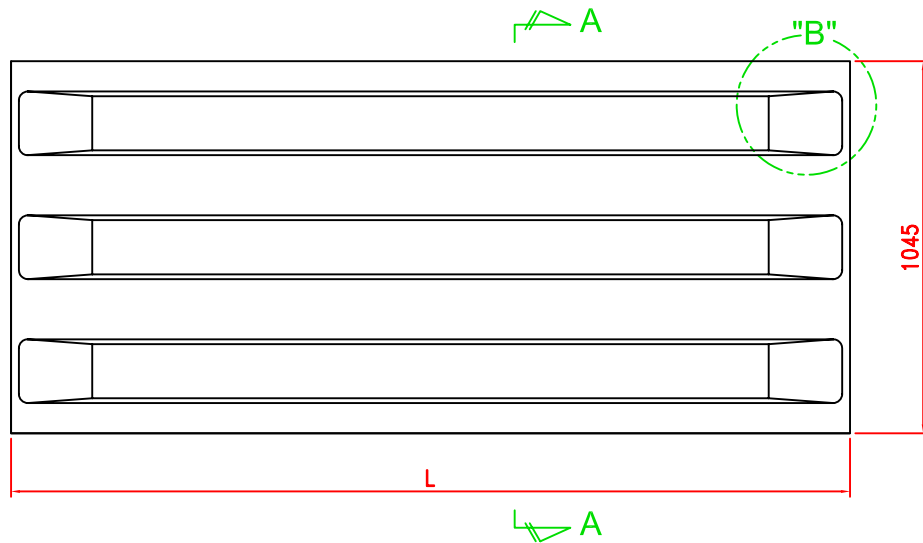

SECTION A - A

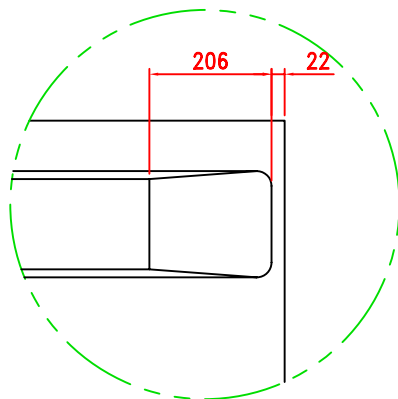

DETAIL "B"

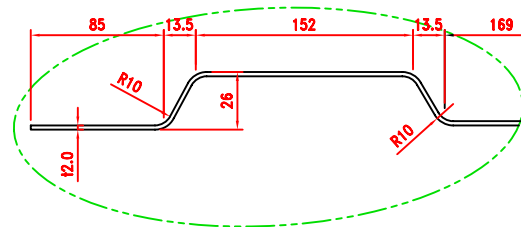

DETAIL "C"

		PART NO.	SPEC
		L&R-D01-03	2.0X1045X2356
		L&R-D01-07	2.0X1045X600
TITLE	Roof Panel (Patch)	WEIGHT	41.476/11.240KGS
SPEC	2.0x1045xL	MATERIAL	CORTEN
PART NO.	L&R-D01-03/07	UNIT	mm
		PAGE NO.	3



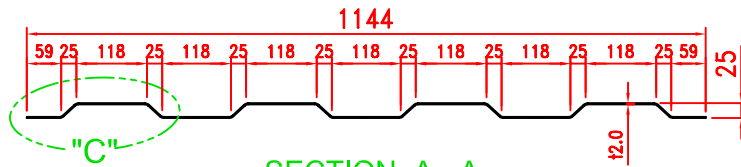
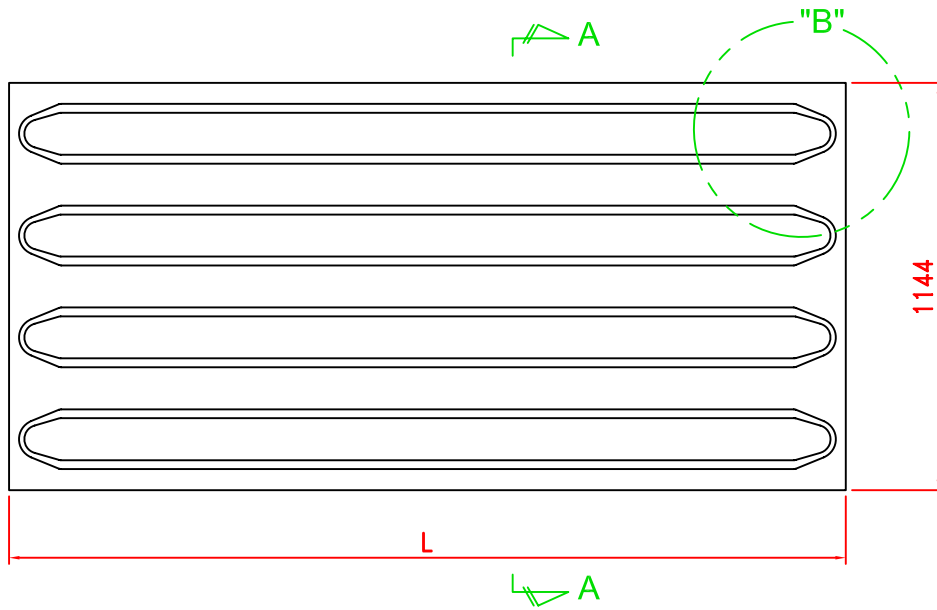

SECTION A - A

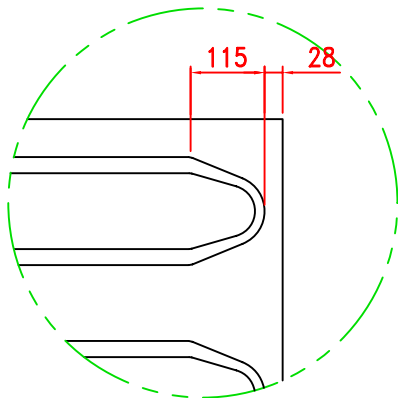

DETAIL "B"

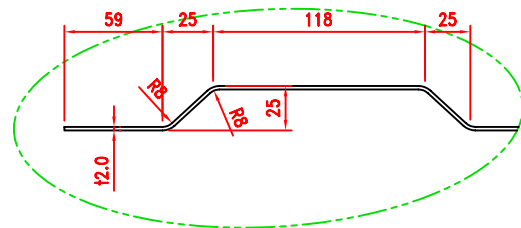

DETAIL "C"

		PART NO.		SPEC	
		L&R-D01-04		2.0X1144X2359	
		L&R-D01-08		2.0X1144X600	
TITLE	Roof Panel (Patch)	WEIGHT		46.158/12.501KGS	
SPEC	2.0x1144xL	MATERIAL		CORTEN	
PART NO.	L&R-D01-04/08	UNIT	mm	PAGE NO.	4



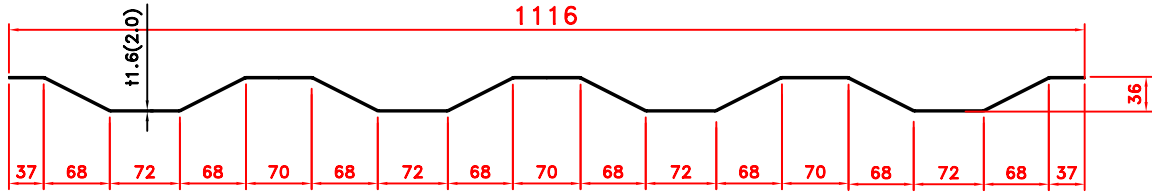

Side Panel

PART NO.	SPEC
L&R-D02-01A	1.6x1116x2400
L&R-D02-01B	1.6x1116x2700
L&R-D02-01C	2.0x1116x2400
L&R-D02-01D	2.0x1116x2700

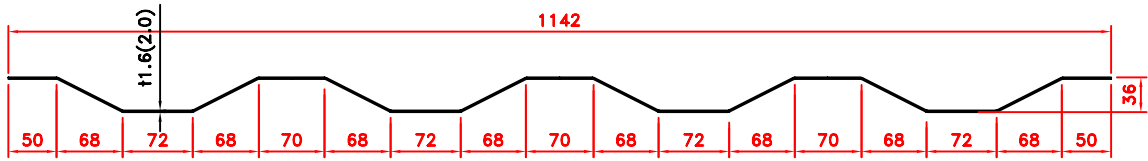

Side Panel

PART NO	SPEC
L&R-D02-05A	2.0X1142X2400
L&R-D02-05A-1	2.0X1142X2380
L&R-D02-05A-2	1.6X1142X2380
L&R-D02-05B	2.0X1142X2700
L&R-D02-05B-1	2.0X1142X2743
L&R-D02-05B-2	1.6X1142X2743
L&R-D02-05B-3	1.6X1142X2700

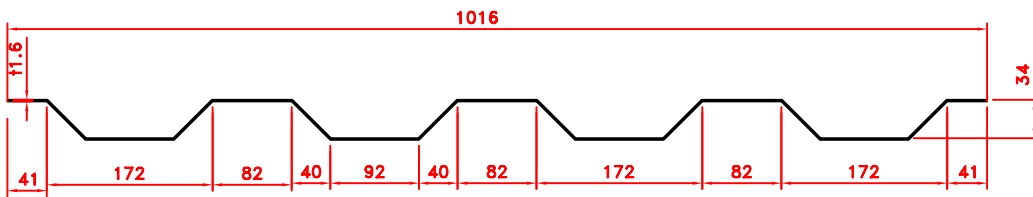

HANJIN Side Panel

PART NO.	SPEC
L&R-D02-04A-1	1.6x1016x2400
L&R-D02-04B-1	1.6x1016x2700

TITLE	Side Panel	WEIGHT	KGS		
SPEC	1.6 (2.0)xWxL	MATERIAL	CORTEN		
PART NO.	L&R-D02	UNIT	mm	PAGE NO.	5



ITEM	SPEC	PART No.
1 CORR.	1.6x278x150	L&R-D02-02A
	1.6x278x300	L&R-D02-02B
2 CORR.	1.6x556x150	L&R-D02-02C
	1.6x556x300	L&R-D02-02D
	1.6x556x600	L&R-D02-02E
4 CORR.	1.6x1116x300	L&R-D02-02F
	1.6x1116x600	L&R-D02-02G
	1.6x1116x1200	L&R-D02-02H

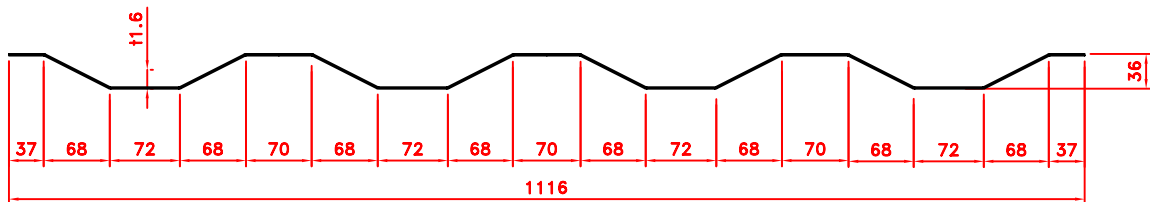
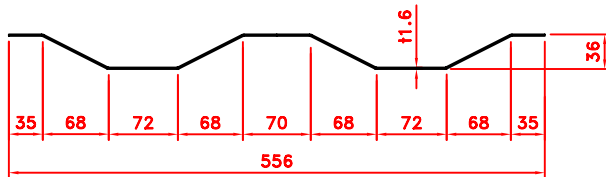
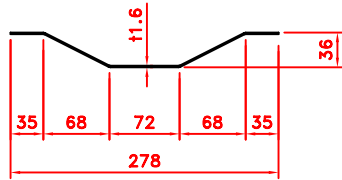

TITLE	Side Panel Patch	MODEL	STANDARD
SPEC	T=1.6	MATERIAL	CORTEN
PART NO.	L&R-D02-02	UNIT	mm
		PAGE NO.	6



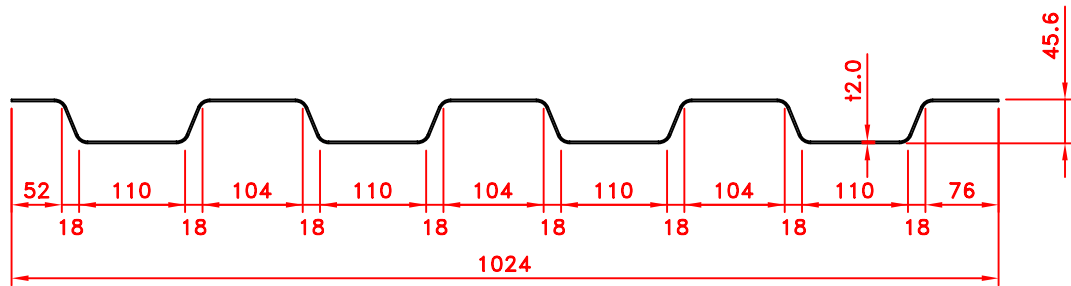

L&R-D03-01A/B

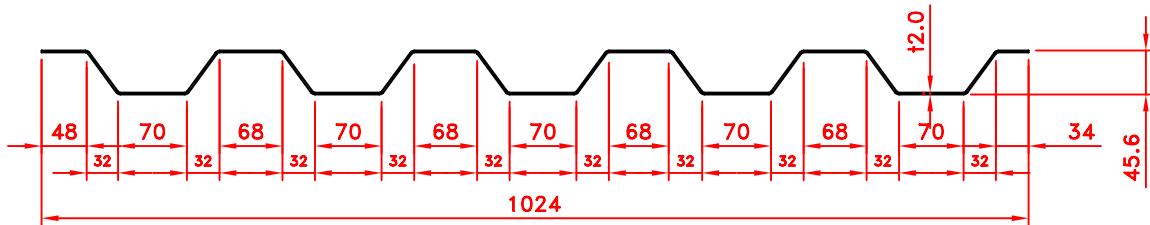

L&R-D03-02A/B

PART NO.	SPEC
L&R-D03-01A	2.0x1024x2400
L&R-D03-01B	2.0x1024x2700
L&R-D03-02A	2.0x1024x2400
L&R-D03-02A	2.0x1024x2700

TITLE	Front End Panel	WEIGHT	KGS
SPEC	2.0x1024x2400/2700	MATERIAL	CORTEN
PART NO.	L&R-D03-01A/B,02A/B	UNIT	mm
		PAGE NO.	7



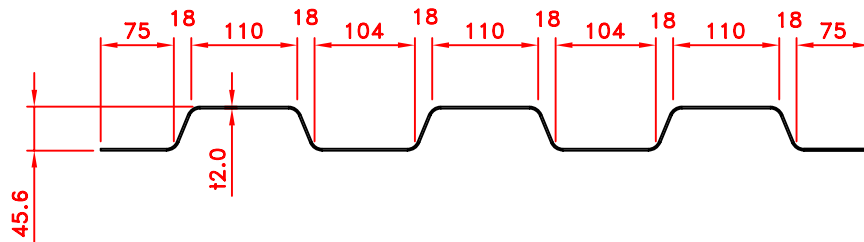
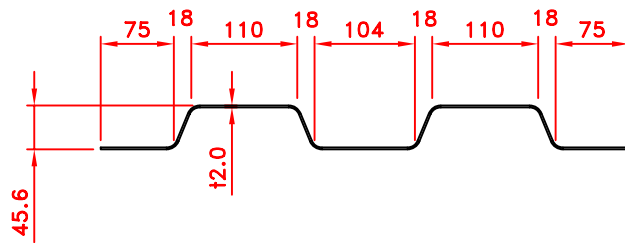
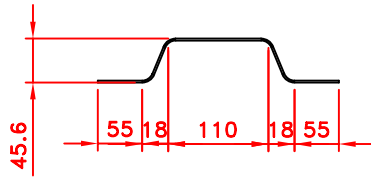

PART NO.		SPEC	
L&R-D03-03		2.0x256x2700	
L&R-D03-04		2.0x546x2700	
L&R-D03-05		2.0x796x2700	
TITLE	Front End Panel	WEIGHT	KGS
SPEC	2.0XWX2700	MATERIAL	CORTEN
PART NO.	L&R-D03-03/04/05	UNIT	mm
		PAGE NO.	8

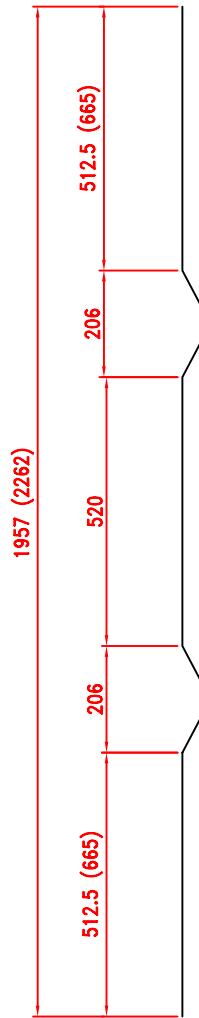

L&R-D04-01A/B

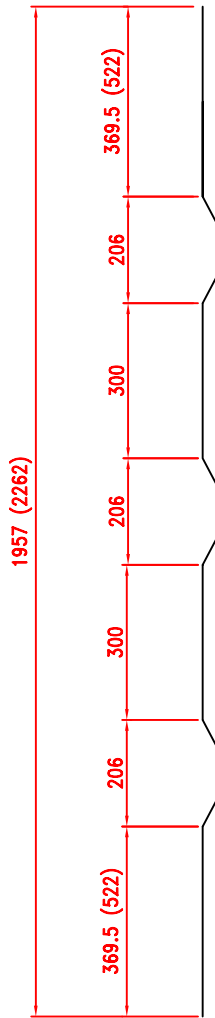

L&R-D04-02A/B

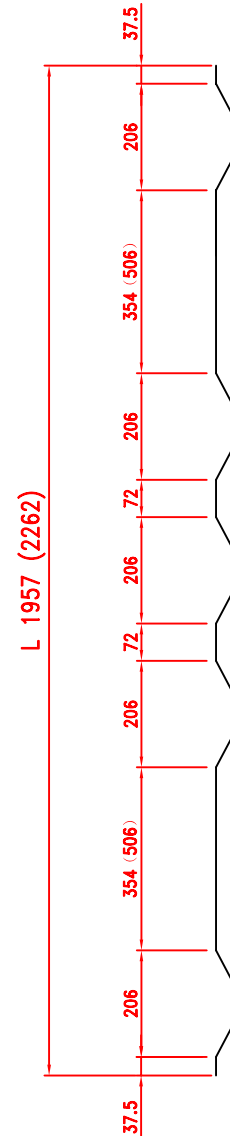

L&R-D04-03A/B

PART NO.	SPEC
L&R-D04-01A	2.0x943x1957 FOR 20'&40'
L&R-D04-01B	2.0x943x2262 FOR 40'HC
L&R-D04-02A	2.0x943x1957 FOR 20'&40'
L&R-D04-02B	2.0x943x2262 FOR 40'HC
L&R-D04-03A	2.0x943x1957 FOR 20'&40'
L&R-D04-03B	2.0x943x2262 FOR 40'HC

TITLE	Door Panel
SPEC	2.0x943x1957/2262
PART NO.	L&R-D04

WEIGHT	KGS
MATERIAL	CORTEN
UNIT	mm
PAGE NO.	9



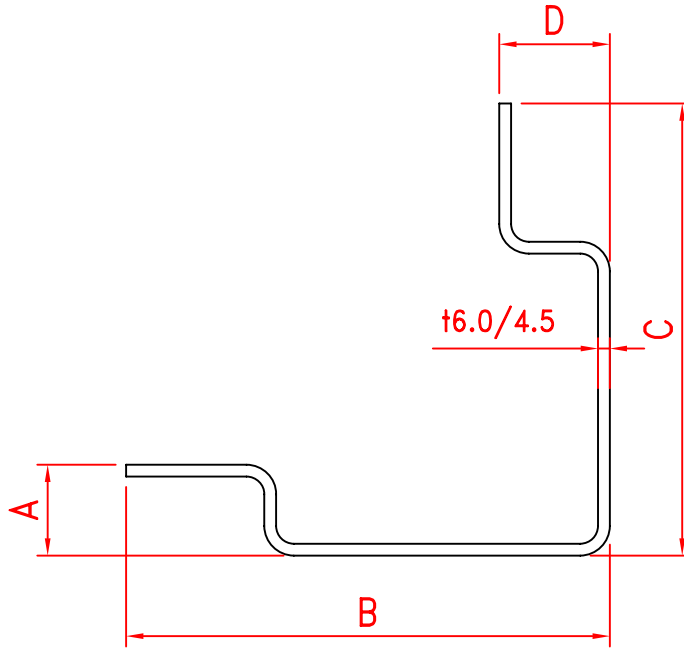

PART NO.	A	D	SPEC
L&R-D05-01A	56	46	6.0X209X225X2400
L&R-D05-01B	56	46	6.0X209X225X2700
L&R-D05-02A	56	46	6.0X229X245X2400
L&R-D05-02B-1	56	46	6.0X229X245X2700
L&R-D05-03A	45	56	6.0X229X214X2420
L&R-D05-03B	45	56	6.0X229X214X2743
L&R-D05-03C	45	56	6.0X229X214X2700
L&R-D05-04A	49.5	54.5	4.5X240.5X220.5X2400
L&R-D05-04B	49.5	54.5	4.5X240.5X220.5X2700
L&R-D05-06A	45	56	6.0X248X232X2400
L&R-D05-06B	45	56	6.0X248X232X2700
L&R-D05-07A	56	46	6.0X246X231X2420
L&R-D05-07B	56	46	6.0X246X231X2743

TITLE	Front Corner Post	WEIGHT	KGS
SPEC	6.0/4.5XBXCXL	MATERIAL	CORTEN
PART NO.	L&R-D05	UNIT	mm
		PAGE NO.	10



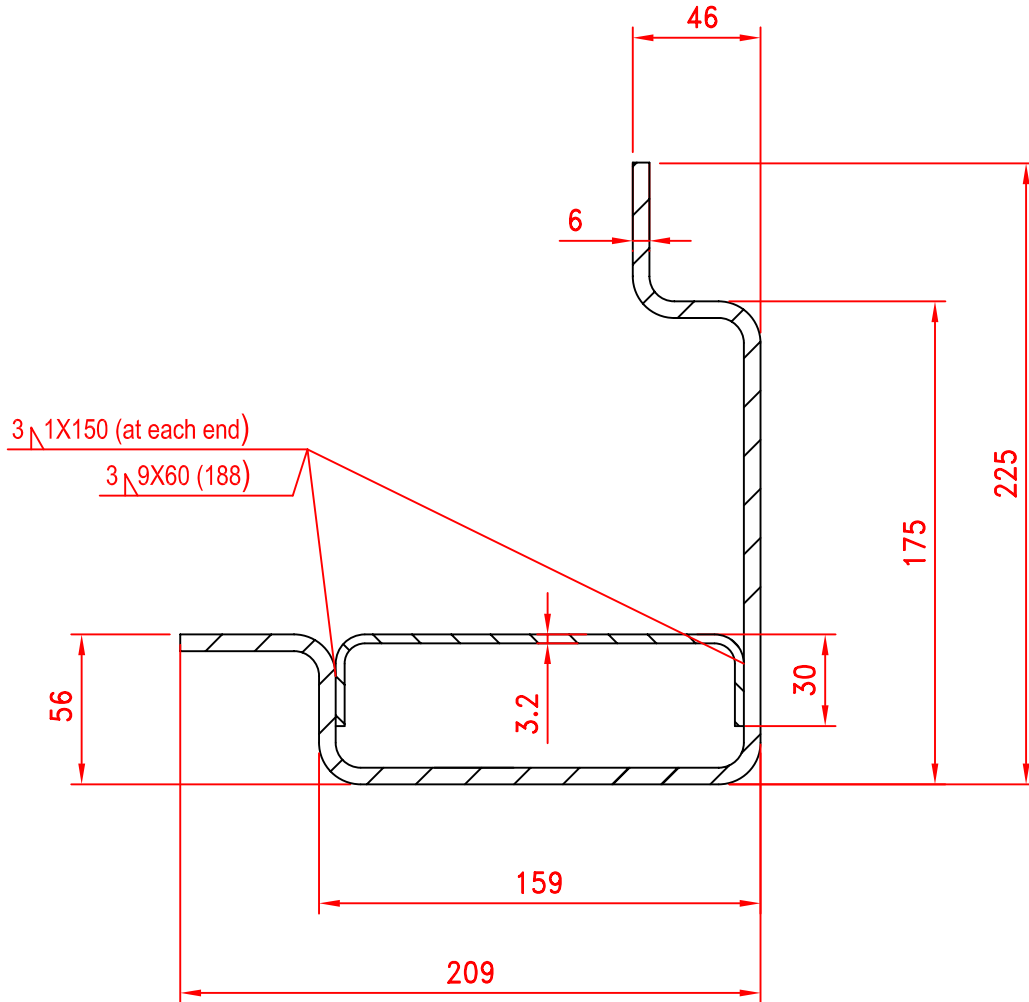

PART NO.		SPEC	
L&R-D05-05A		6.0X209X225X2420&3.2X195X2420	
L&R-D05-05B		6.0X209X225X2720&3.2X195X2720	
TITLE	Front Corner Post with reinforcement inside	WEIGHT	66.915 / 75.282KGS
SPEC	L=2420 / 2720	MATERIAL	CORTEN
PART NO.	L&R-D05-05A/B	UNIT	mm
		PAGE NO.	11



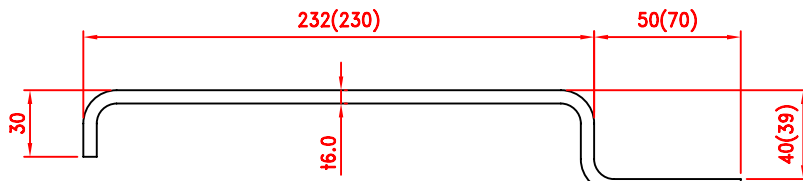

Rear Corner Post Outer

PART NO.	SPEC
L&R-D06-01A	6.0X50X40X232X2400
L&R-D06-01B	6.0X50X40X232X2700
L&R-D06-02A	6.0X70X39X230X2400
L&R-D06-02B	6.0X70X39X230X2700

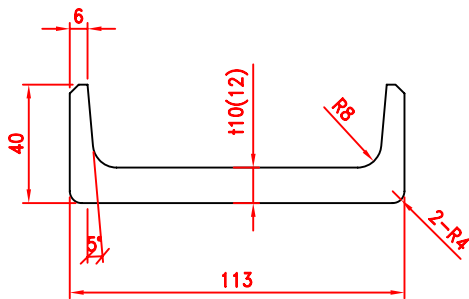

Rear Corner Post Inner

PART NO.	SPEC
L&R-D06-03A	10X113X40X2353
L&R-D06-03B	12X113X40X2353
L&R-D06-03C	12X113X40X2657

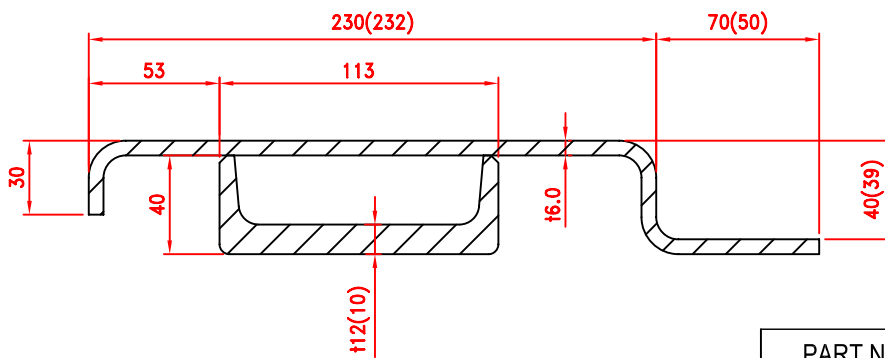

Rear Corner Post

PART NO.	SPEC
L&R-D06-04A	6.0X50X40X232X2400&10X113X40X2353
L&R-D06-04B	6.0X50X40X232X2400&12X113X40X2353
L&R-D06-04C	6.0X50X40X232X2700&12X113X40X2657
L&R-D06-05A	6.0X70X39X230X2400&12X113X40X2353
L&R-D06-05B	6.0X70X39X230X2700&12X113X40X2657

TITLE	Rear Corner Post	WEIGHT	
SPEC	6.0X50/70X40/39X232X2400/2700	MATERIAL	
PART NO.	L&R-D06	UNIT	mm
		PAGE NO.	12



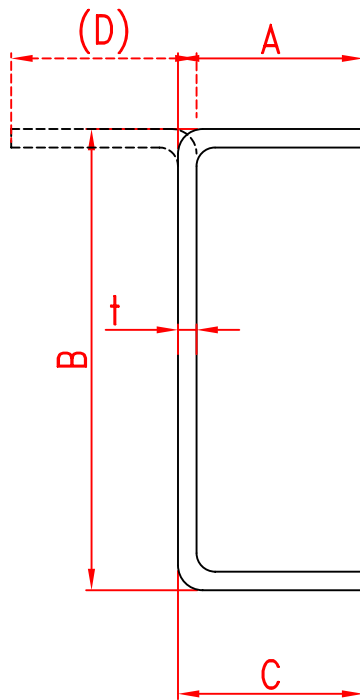

PART NO.	A	B	C	SPEC
L&R-D07-01A	80	122	45	4.5X45X122X80X2400
L&R-D07-01B	80	122	50	4.5X50X122X80X2400
L&R-D07-02A	45	85	45	4.5X45X85X45X2400
L&R-D07-02B	45	100	45	4.5X45X100X45X2400
L&R-D07-02C	45	122	45	4.5X45X122X45X2400
L&R-D07-02D	60	120	60	4.5X60X120X60X2420
L&R-D07-02E	60	120	80	4.5X60X120X80X2420
L&R-D07-02F	50	120	50	4.5X50X120X50X2400
L&R-D07-03A	45	122	80	4.0X45X122X80X2400
L&R-D07-03B	45	85	45	4.0X45X85X45X2400
L&R-D07-03C	45	100	45	4.0X45X100X45X2400
L&R-D07-03D	45	122	45	4.0X45X122X45X2400
PART NO.	D	B	C	SPEC
CIMC-D07-05A	75	121	50	4.5X75X121X50X2420

TITLE	Cross Member	WEIGHT	
SPEC	4.0/4.5XA(D)XBXCXL	MATERIAL	CORTEN
PART NO.	L&R-D07	UNIT	mm
		PAGE NO.	13



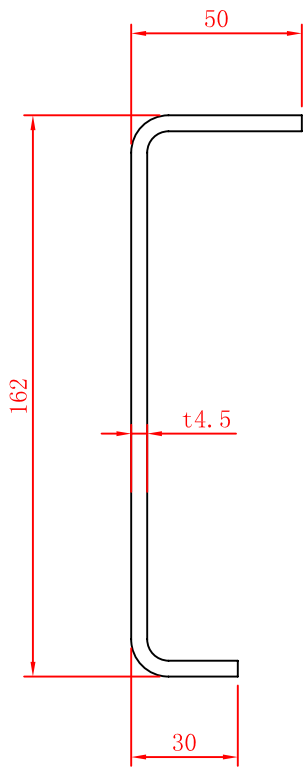

L&R-D08-01C

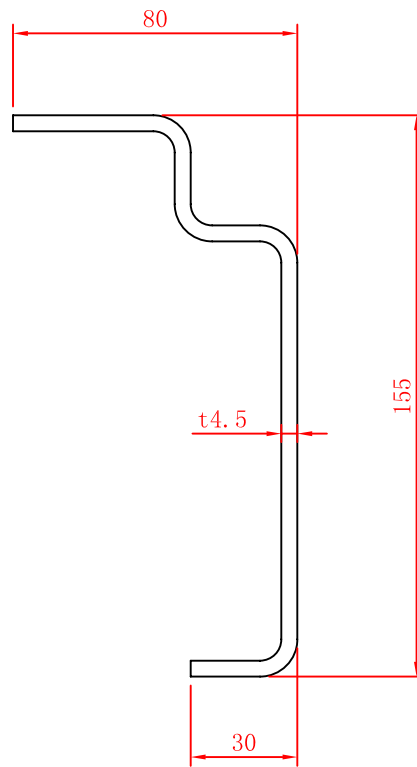

L&R-D08-02

		PART NO.	SPEC
		L&R-D08-01C	4.5X50X162X30X5702
		L&R-D08-02	4.5X50X155X30X5702
TITLE	Bottom Side Rail	WEIGHT	KGS
SPEC	4.5X50X162/155X30X5702	MATERIAL	CORTEN
PART NO.	L&R-D08-01C/02	UNIT	mm
		PAGE NO.	14

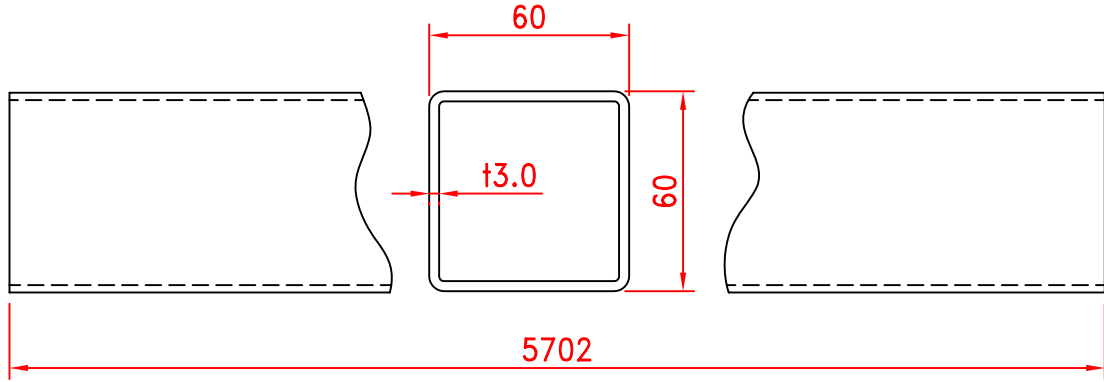

L&R-D09-01A

Top Side Rail

3.0X60X60X5702

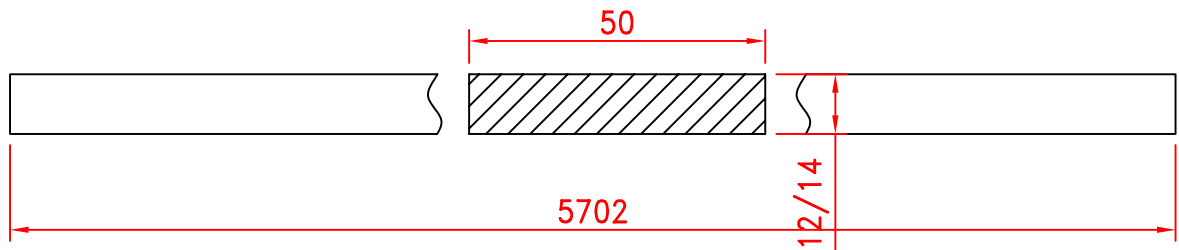

L&R-D09-02A/C

Top Side Rail

12/14X50X5702

TITLE	Top Side Rail	WEIGHT	KGS		
SPEC		MATERIAL			
PART NO.	L&R-D09-01/02	UNIT	mm	PAGE NO.	15



L&R

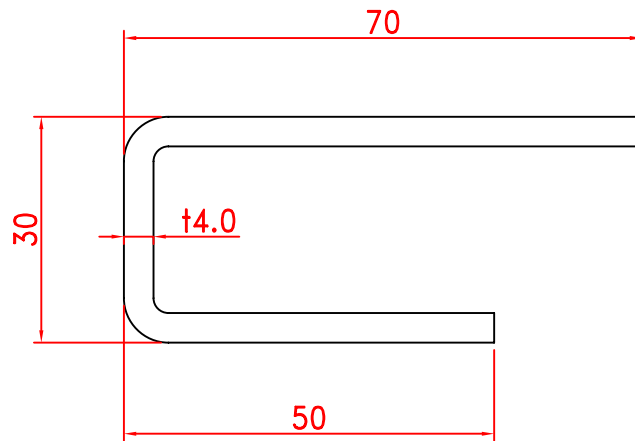

"U" Type

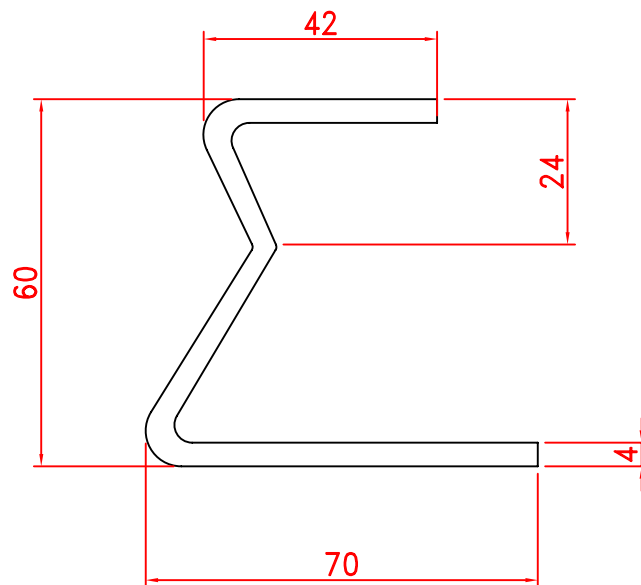

"W" Type

TITLE	Top Side Rail	WEIGHT	10.174 / 12.434 KGS		
SPEC	T = 4.0 L = 2400	MATERIAL	CORTEN		
PART NO.	L&R-D09-03/04	UNIT	mm	PAGE NO.	16

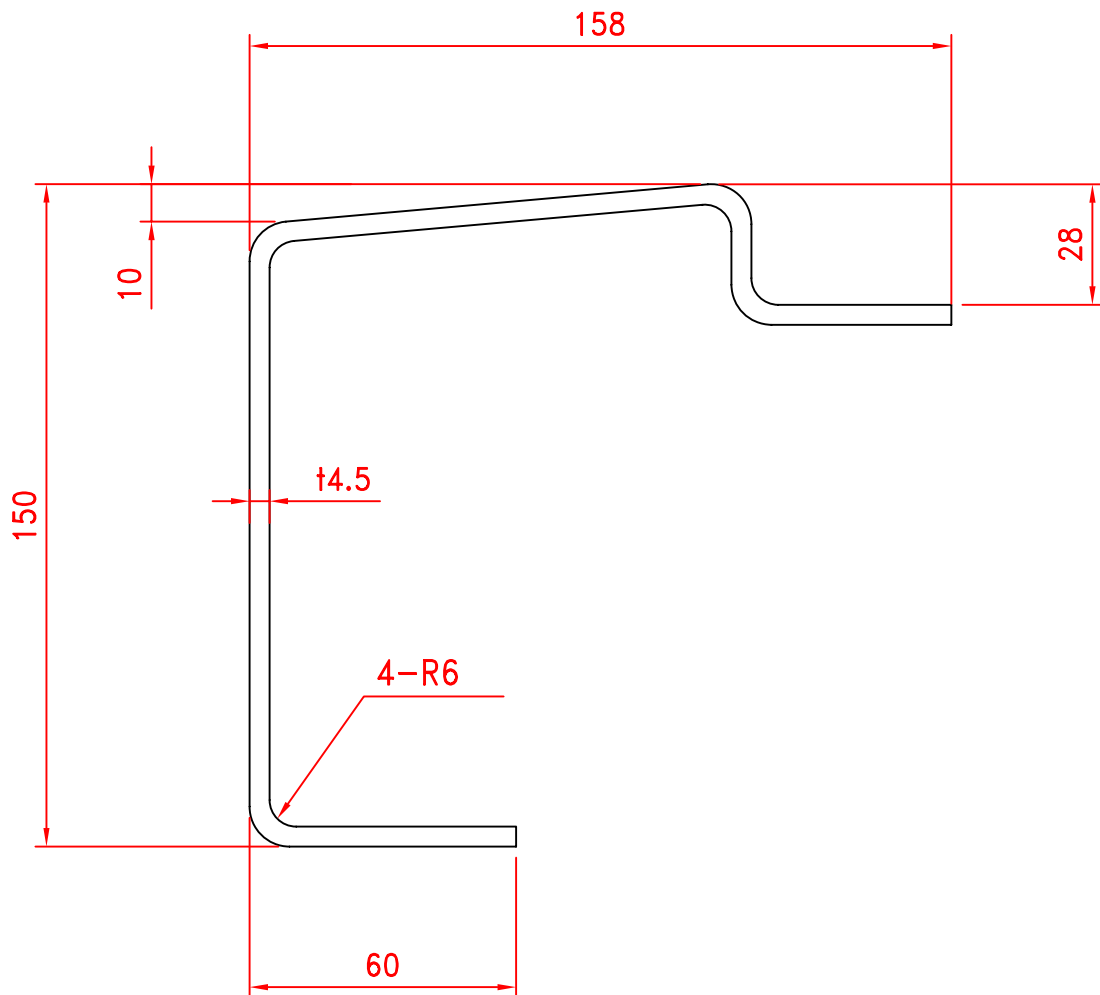

TITLE	Door Sill	WEIGHT	30.690KGS	
SPEC	4.5X158X150X2400	MATERIAL	CORTEN	
PART NO.	L&R-D10-01	UNIT	mm	PAGE NO. 17



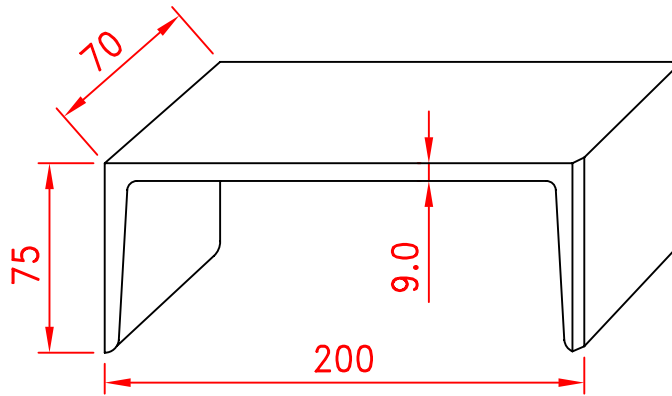

L&R-D10-03 C-Chanel

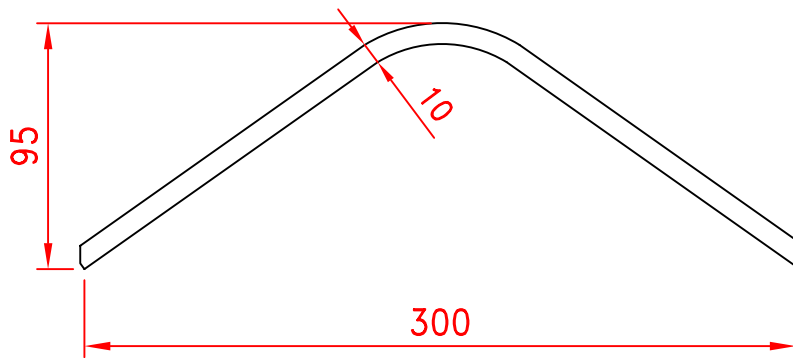

L&R-D10-04 V-Chanel

TITLE	C-Chanel/V-Chanel	WEIGHT	1.720 / 2.000 KGS	
SPEC	9.0x200X75X70 / 10x300x95x70	MATERIAL		
PART NO.	L&R-D10-03/04	UNIT	mm	PAGE NO. 18

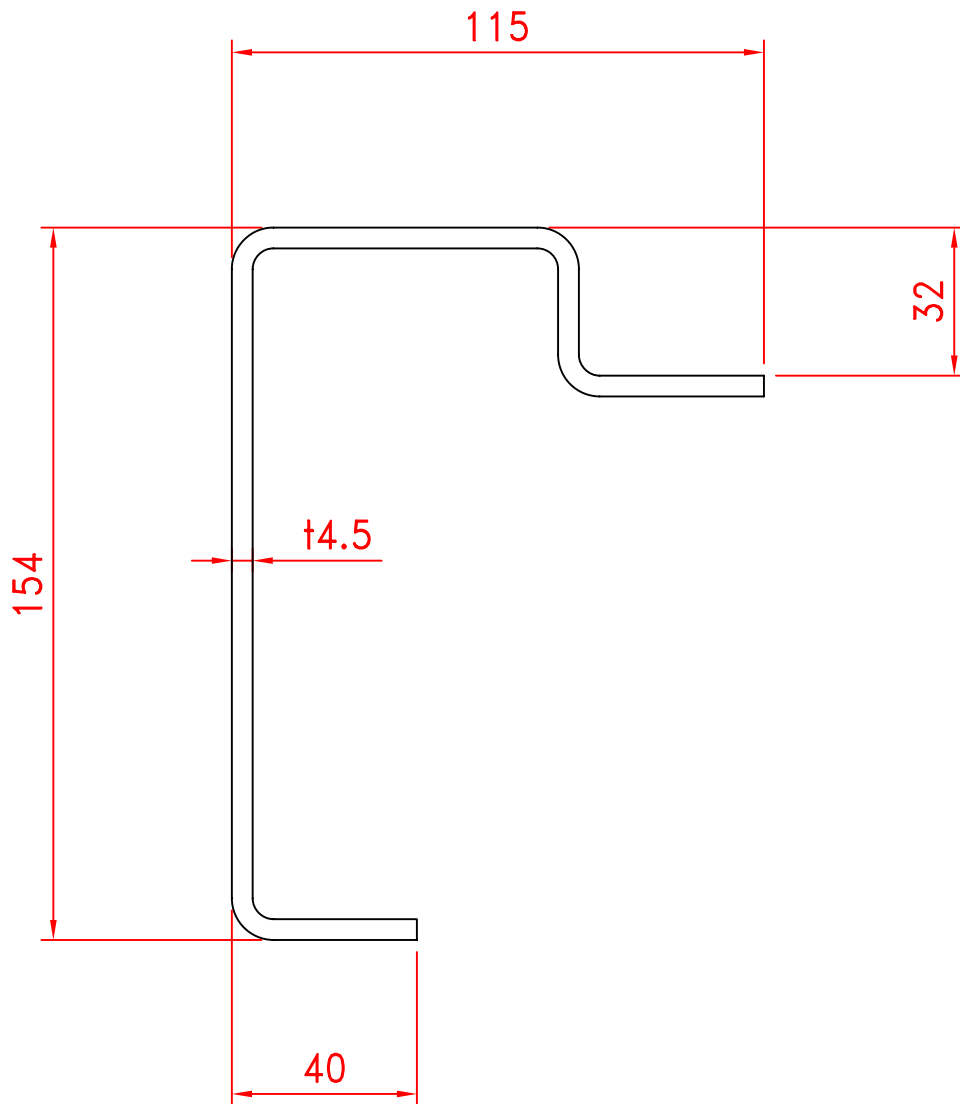

TITLE	Front Bottom Rail	WEIGHT	26.621KGS	
SPEC	4.5X115X154X2400	MATERIAL	CORTEN	
PART NO.	L&R-D11-01	UNIT	mm	PAGE NO. 19



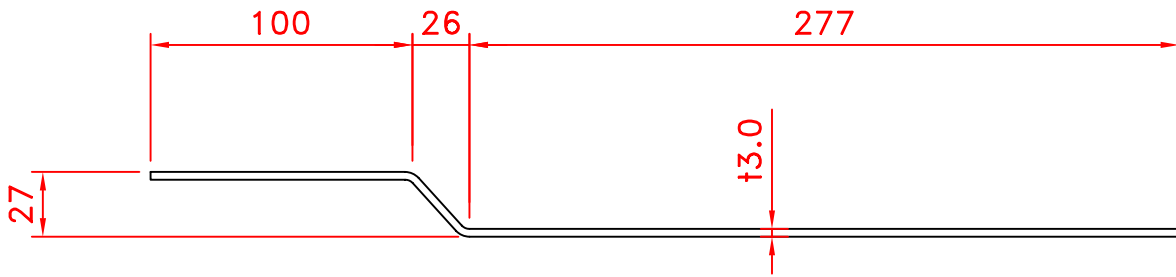

L&R-D12-01

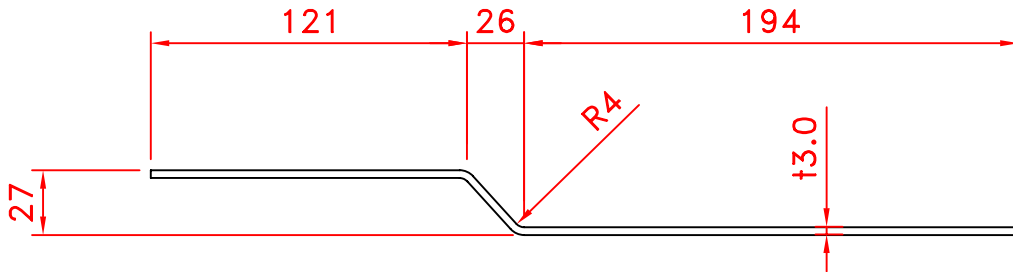

L&R-D12-02

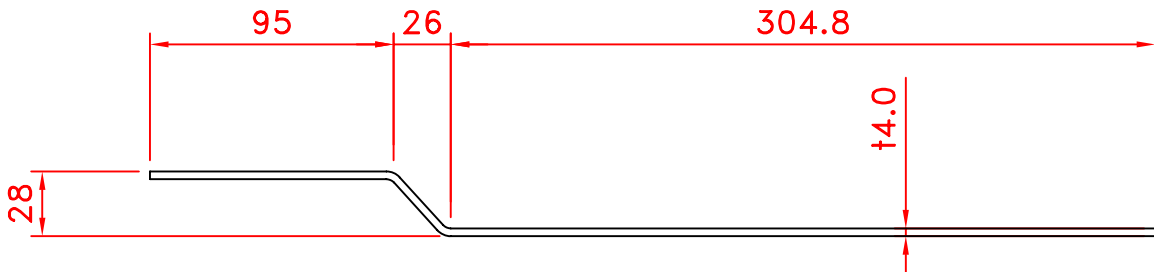

L&R-D12-03

PART NO.	SPEC
L&R-D12-01	3.0X100X26X277X2400
L&R-D12-02	3.0X121X26X194X2400
L&R-D12-03	4.0X95X26X304.8X2420

TITLE	Top end rail	WEIGHT	
SPEC	3.0(4.0)XAX26XBXL	MATERIAL	CORTEN
PART NO.	L&R-D12	UNIT	mm
		PAGE NO.	20

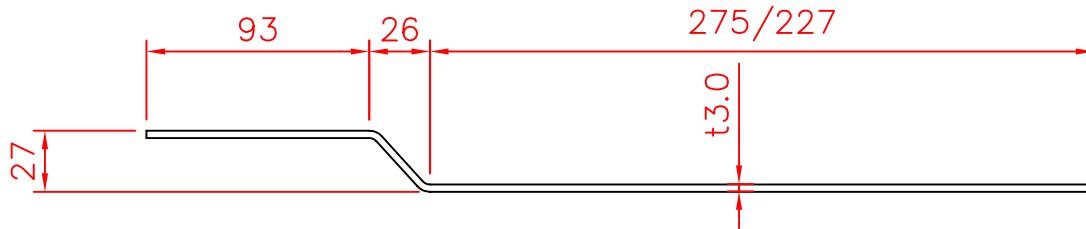

L&R-D13-01/02

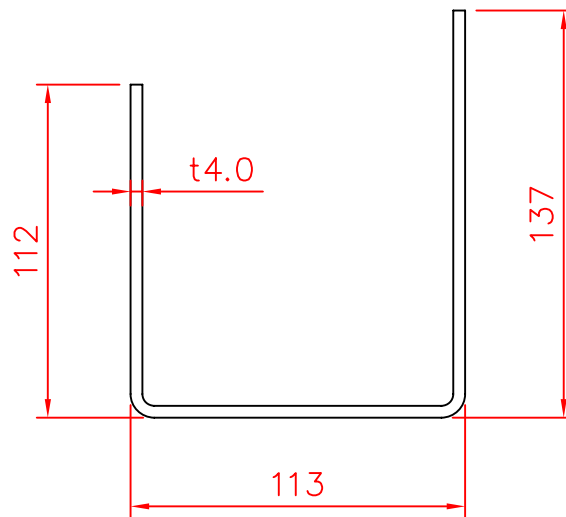

L&R-D13-03

PART NO.		SPEC	
L&R-D13-01		3.0X394X2400	
L&R-D13-02		3.0X346X2400	
L&R-D13-03		4.0X112X113X137X2400	
TITLE	Door Header Upper/Lower	WEIGHT	22.608 / 19.895 / 26.150KGS
SPEC		MATERIAL	CORTEN
PART NO.	L&R-D13	UNIT	mm
		PAGE NO.	21

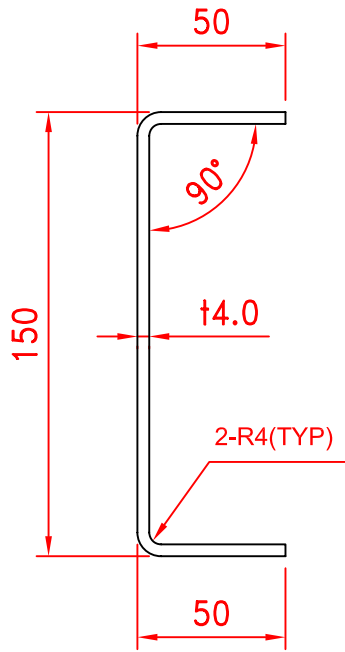

L&R-D14-01 Door Rail

4.0x50x150x50x943

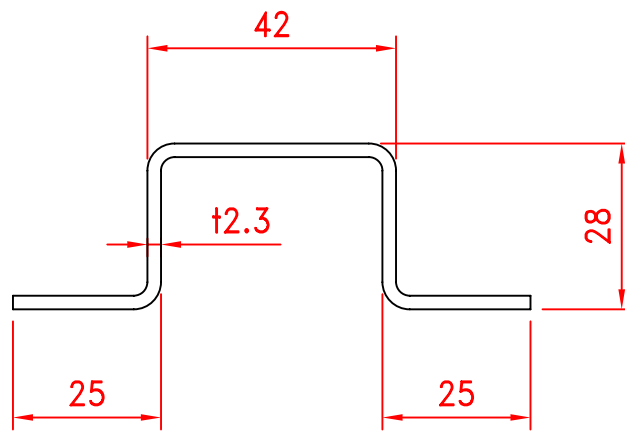

L&R-D15-01 Floor Space

2.3X42X28X25X3000

TITLE	Door Rail / Floor Space	MODEL	KGS		
SPEC		MATERIAL	CORTEN		
PART NO.	L&R-D14/15-01	UNIT	mm	PAGE NO.	22

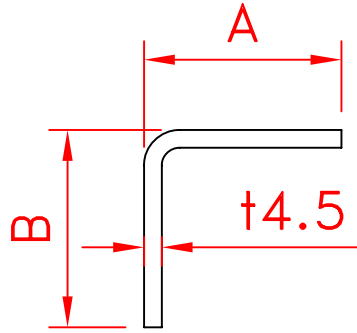

A	B	PART NO.
50	30	L&R-D16-01A
50	50	L&R-D16-01B
90	60	L&R-D16-01C
100	30	L&R-D16-01D
100	40	L&R-D16-01E
100	45	L&R-D16-01F
100	50	L&R-D16-01G
100	80	L&R-D16-01H
110	45	L&R-D16-01I
110	50	L&R-D16-01J
115	45	L&R-D16-01K
115	50	L&R-D16-01L
120	30	L&R-D16-01M
120	40	L&R-D16-01N
120	45	L&R-D16-01O
120	50	L&R-D16-01P
120	60	L&R-D16-01Q
120	80	L&R-D16-01R
140	40	L&R-D16-01S
150	60	L&R-D16-01T

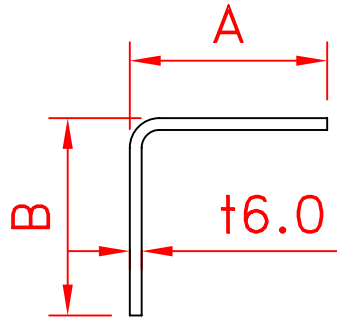

A	B	PART NO.
130	120	L&R-D16-02A
100	100	L&R-D16-02B
135	150	L&R-D16-02C
50	30	L&R-D16-02D
60	30	L&R-D16-02E
55	35	L&R-D16-02F

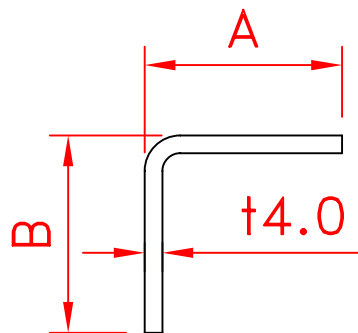

A	B	PART NO.
50	30	L&R-D16-03A
50	50	L&R-D16-03B
90	60	L&R-D16-03C
100	30	L&R-D16-03D
110	45	L&R-D16-03E
110	80	L&R-D16-03F
115	45	L&R-D16-03G
120	30	L&R-D16-03H
140	40	L&R-D16-03I
150	60	L&R-D16-03J

TITLE	Angle	WEIGHT			
SPEC	L = 2400	MATERIAL		CORTEN	
PART NO.	L&R-D16-0X	UNIT	mm	PAGE NO.	23

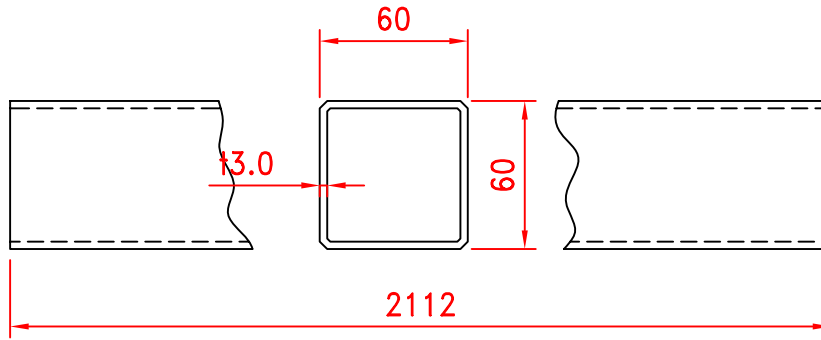

Top / Bottom End Rail (Square Tube)

3.0X60X60X2112

L&R-D17-01A

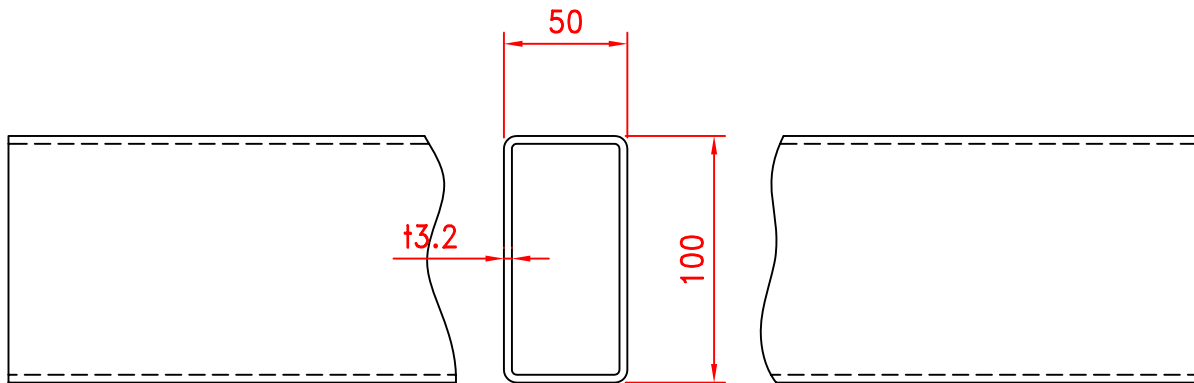

Door Edge Member

3.2X50X100X2248/2552

L&R-D18-01A/B

		PART NO.	SPEC	
		L&R-D18-01A	3.2X50X100X2248	
		L&R-D18-01B	3.2X50X100X2552	
TITLE	Square Tube / Door Edge Member	WEIGHT	KGS	
SPEC		MATERIAL	CORTEN	
PART NO.	L&R-D17/18	UNIT	mm	PAGE NO. 24

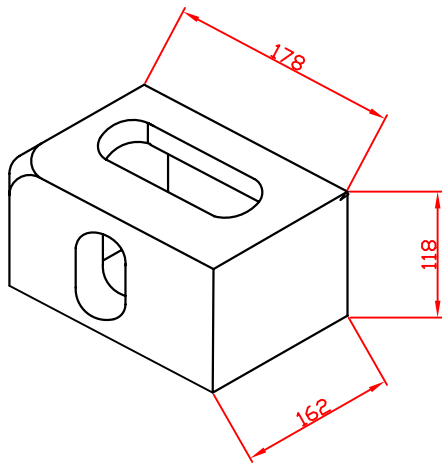

A

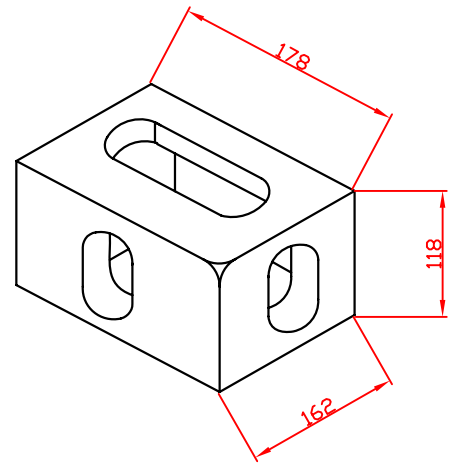

C

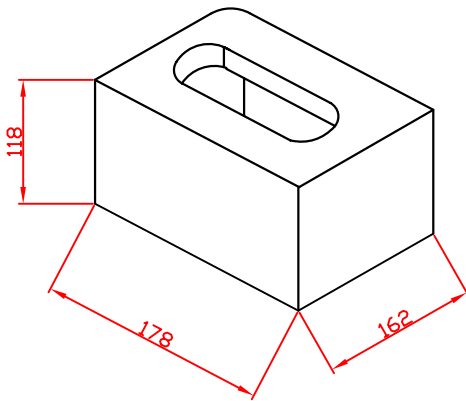

B

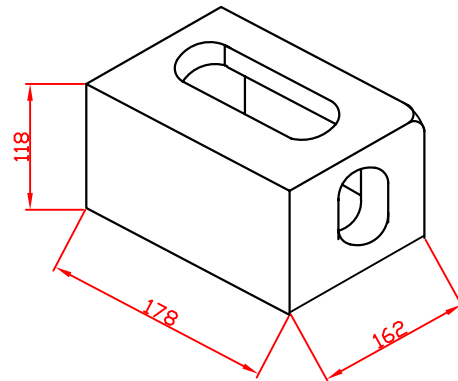

D

ITEM	DESCRIPTION
A	L&R-D19-01-1 BL, FOR FRONT LOWER RH OR REAR LOWER LH POSTION
B	L&R-D19-01-2 BR, FOR FRONT LOWER LH OR REAR LOWER RH POSTION
C	L&R-D19-01-3 TL, FOR FRONT TOP RH OR REAR TOP LH POSTION
D	L&R-D19-01-4 TR, FOR FRONT TOP LH OR REAR TOP RH POSTION

TITLE	Corner Casting	WEIGHT	88.00KGS
SPEC	178X162X118	MATERIAL	SCW490MOD
PART NO.	L&R-D19-01	UNIT	mm
		PAGE NO.	25



L&R

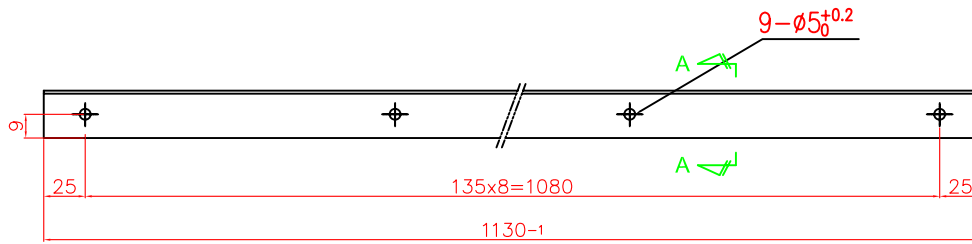

L&R-D20-01A

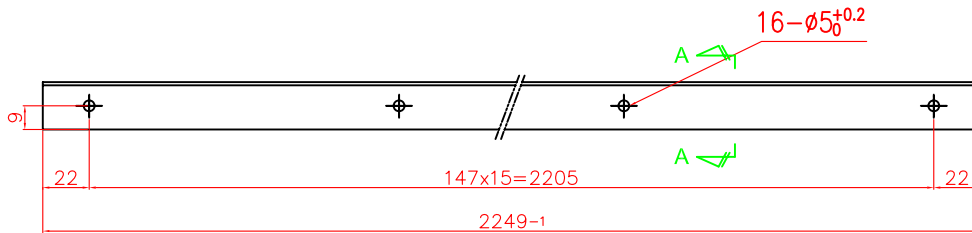

L&R-D20-01B

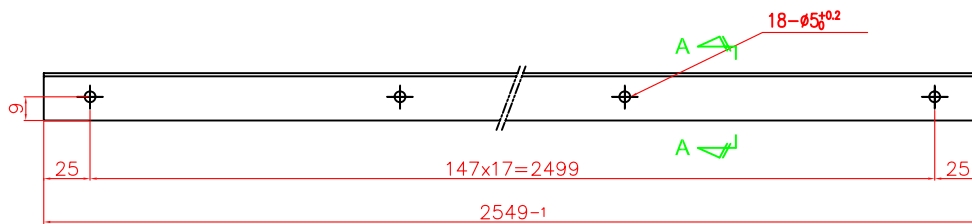

L&R-D20-01C

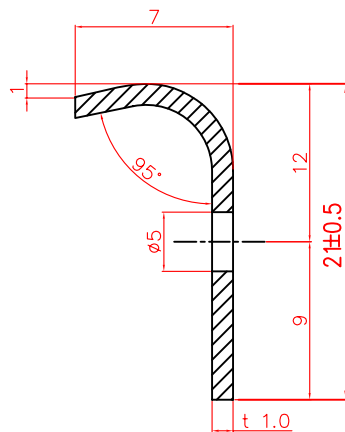

SECTION A - A (S=8/1)

1 / 1 SET	
horizontal	4 PCS
vertical	3 PCS

TITLE	Stainless Door Seal Retainer Strip	WEIGHT	0.15/0.305/0.305kgs	
SPEC	t1.0x21x7xL	MATERIAL	SUS304	
PART NO.	L&R-D20-01A/B/C	UNIT	mm	PAGE NO. 26



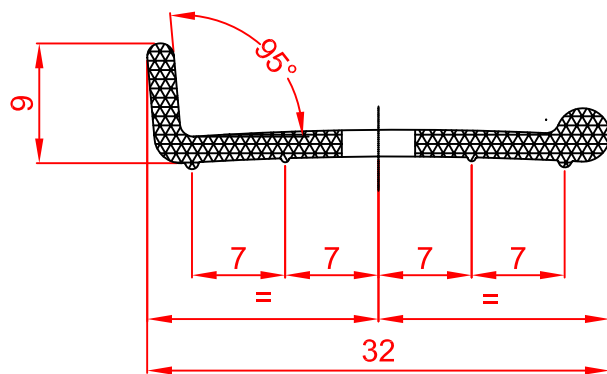
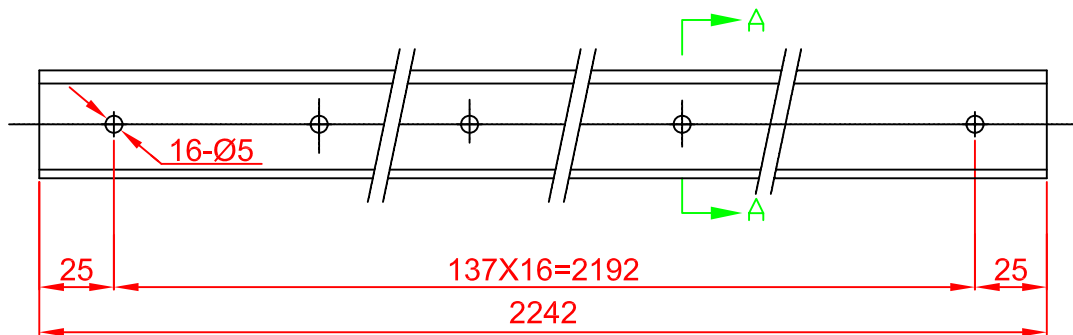
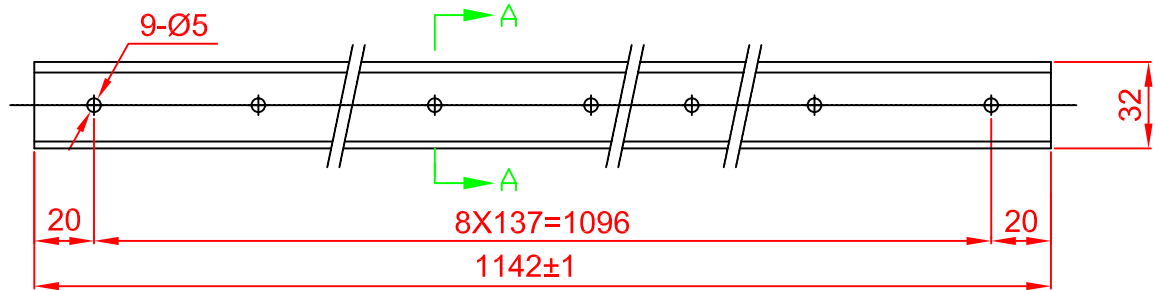

SECTION A-A

1 / 1 SET	
horizontal	4 PCS
vertical	3 PCS

TITLE	ABS Door Seal Retainer Strip	WEIGHT	
SPEC	t2.0x32x9xL	MATERIAL	ABS
PART NO.	L&R-D20-03A/B/C	UNIT	mm
		PAGE NO.	27

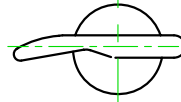
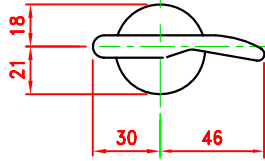
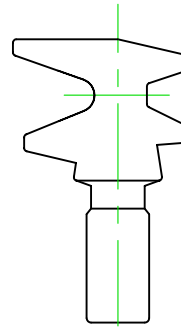
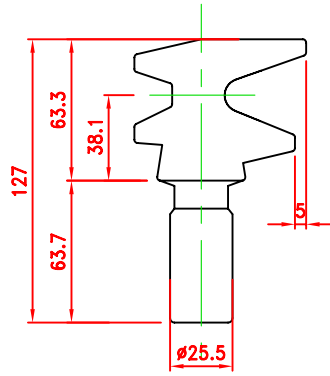

L&R-D23-01B
RH

L&R-D23-01A
LH

Cam(LH/RH)

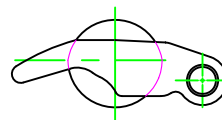
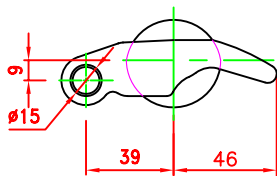
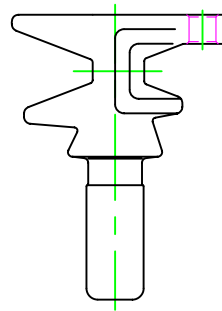
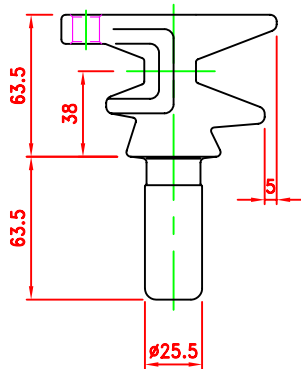

L&R-D23-01C
RH

L&R-D23-01D
LH

Security Cam(LH/RH)

TITLE	Cam(LH/RH)	WEIGHT	0.61/0.61/0.75/0.75KGS
MODEL	BE2566M	MATERIAL	20Mn
PART NO.	L&R-D23-01A/B/C	UNIT	mm
		PAGE NO.	28



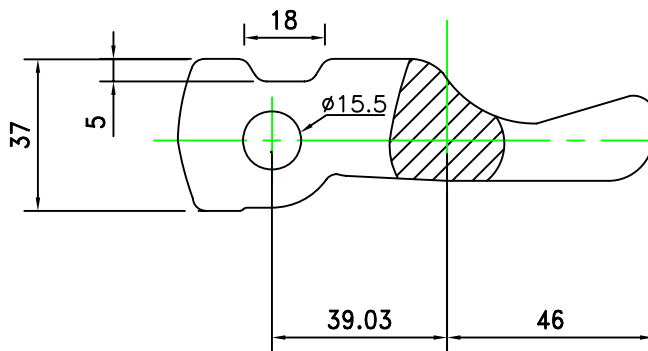
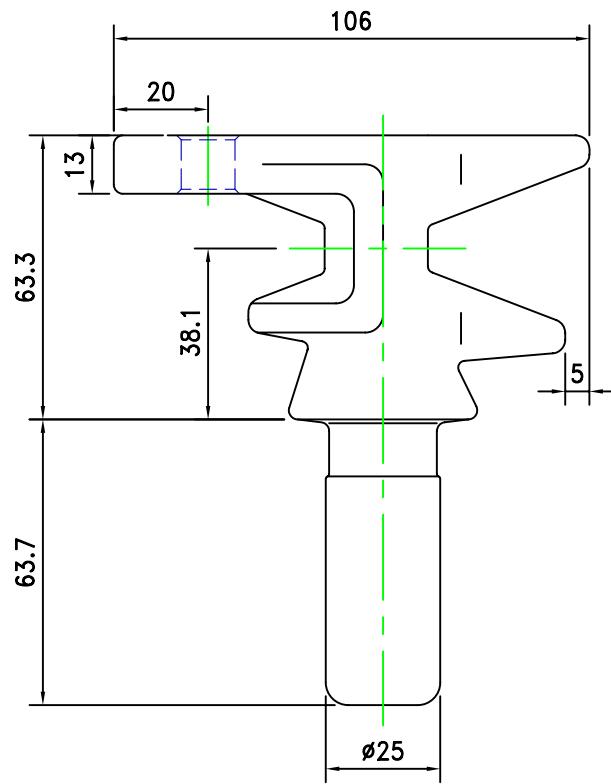

TITLE	Security Cam R.H	WEIGHT	KGS
MODEL	BE2566M	MATERIAL	20Mn
PART NO.	L&R-D23-01G	UNIT	mm
		PAGE NO.	29

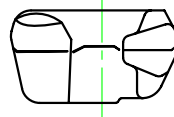
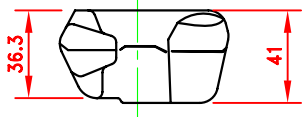
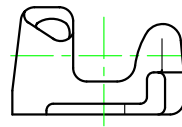
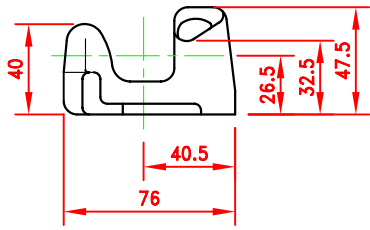

L&R-D23-02A

L&R-D23-02B

LH

RH

Keeper (LH/RH)
For Corrugated Door

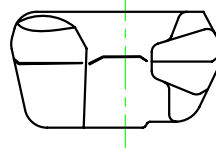
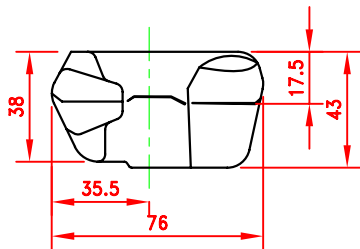
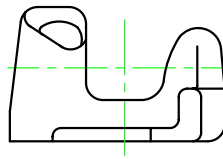
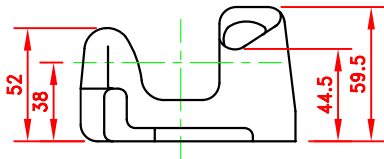

L&R-D23-02C

L&R-D23-02D

LH

RH

Keeper(LH/RH)
For Flat Door

TITLE	Keeper (LH/RH)	WEIGHT	0.40/0.40/0.60/0.60KGS	
MODEL	BE2566M	MATERIAL	20Mn	
PART NO.	L&R-D23-02A/B/C/D	UNIT	mm	PAGE NO. 30



L&R-D23-02E
Security Keeper R.H.

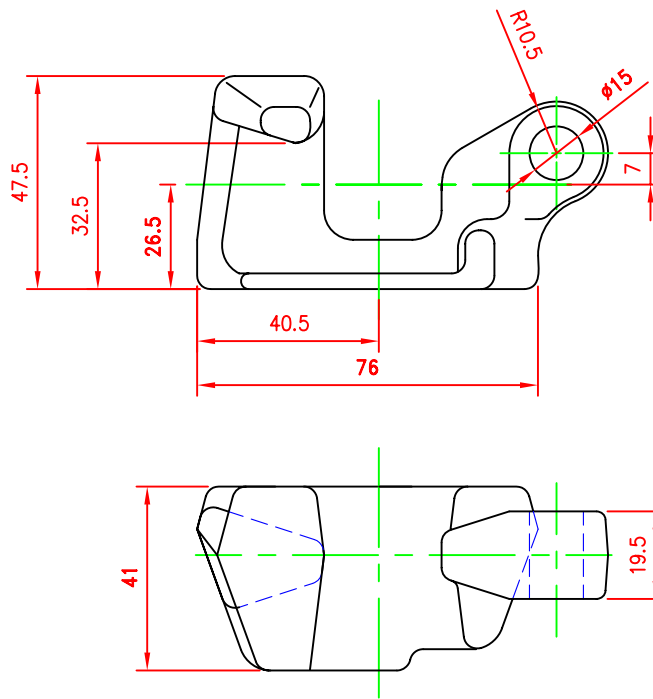

L&R-D23-02G
Security Keeper R.H.
Maersk Type

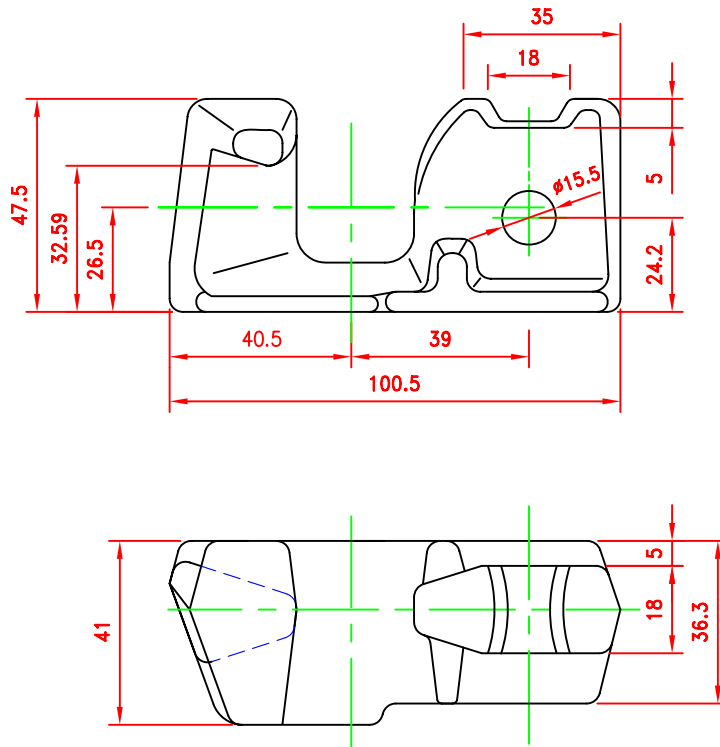

TITLE	Security Keeper	WEIGHT	0.45 / 0.60 KGS	
MODEL	BE2566M	MATERIAL	20Mn	
PART NO.	L&R-D23-02E/G	UNIT	mm	PAGE NO. 31

Bearing Bracket Outer L

L&R-D23-03

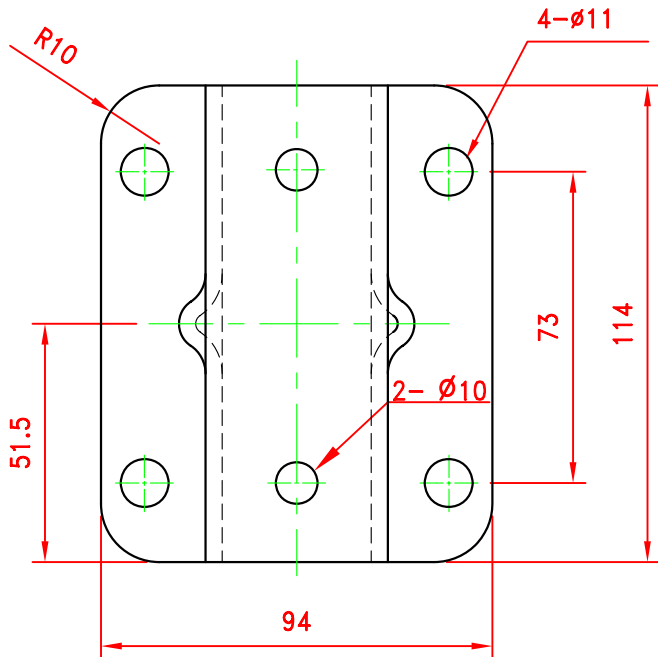
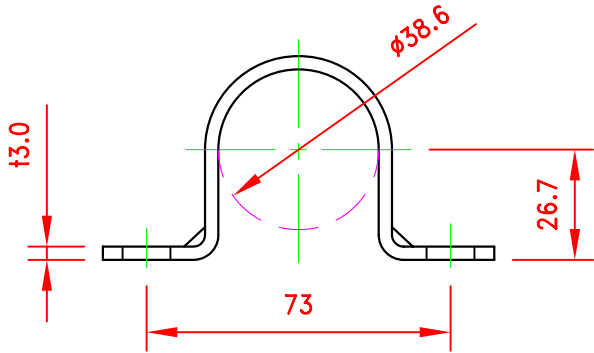

Bearing Bracket Inner L

L&R-D23-04

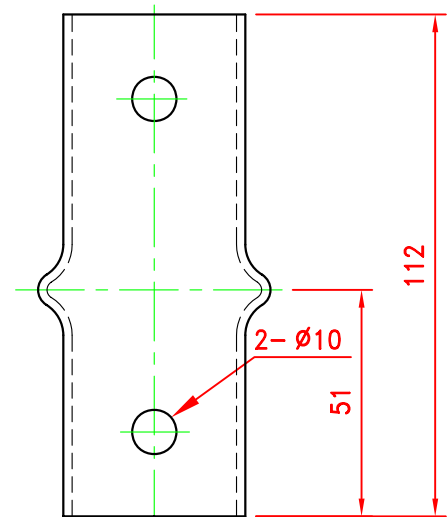
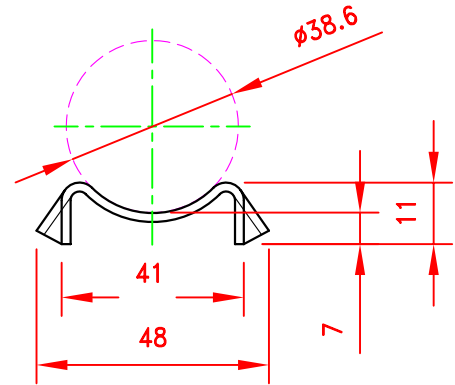

TITLE	Bearing Bracket L	WEIGHT	0.43/0.09KGS
MODEL	BE2566M	MATERIAL	SS400
PART NO.	L&R-D23-03/04	UNIT	mm
		PAGE NO.	32

Bearing Bracket Outer S 小托架 (外)

L&R-D23-05

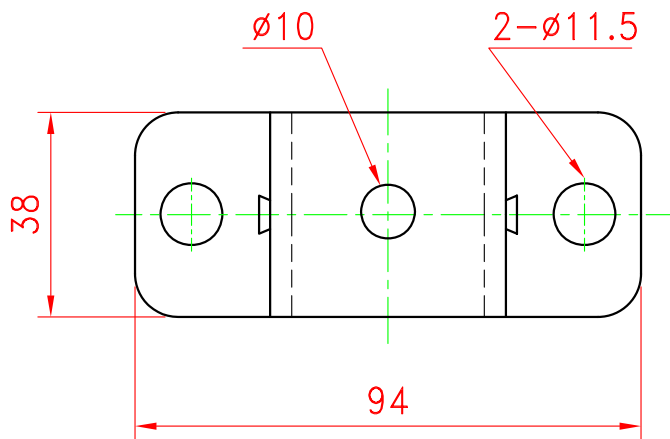
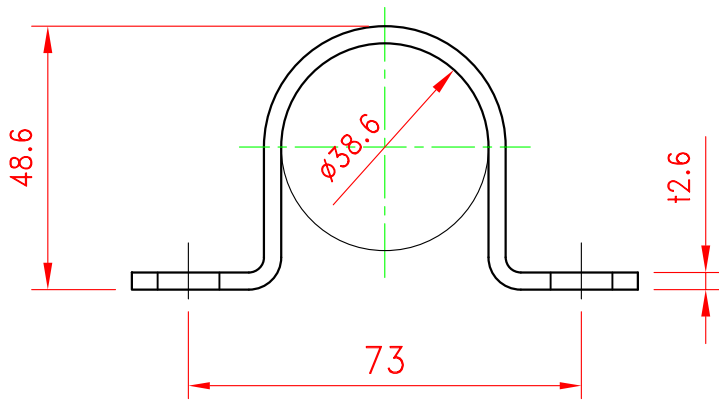

Bearing Bracket Inner S 小托架 (内)

L&R-D23-06

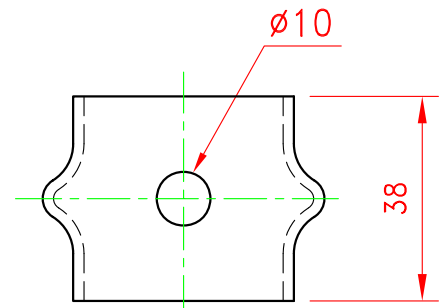
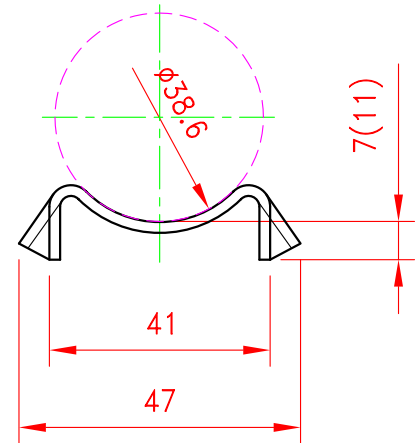

TITLE	Bearing Bracket S	WEIGHT	0.12/0.03KGS
MODEL	BE2566M	MATERIAL	SS400
PART NO.	L&R-D23-05/06	UNIT	mm
		PAGE NO.	33

L&R-D23-07A

Forging Type

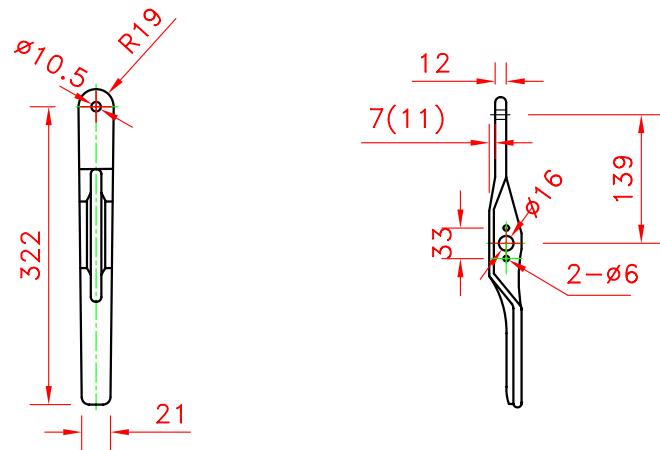

L&R-D23-07B

Press Type

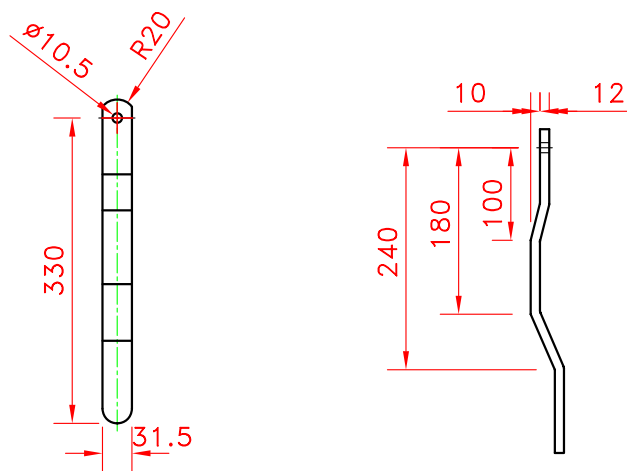

L&R-D23-07C

Forging Type (Without Hole)

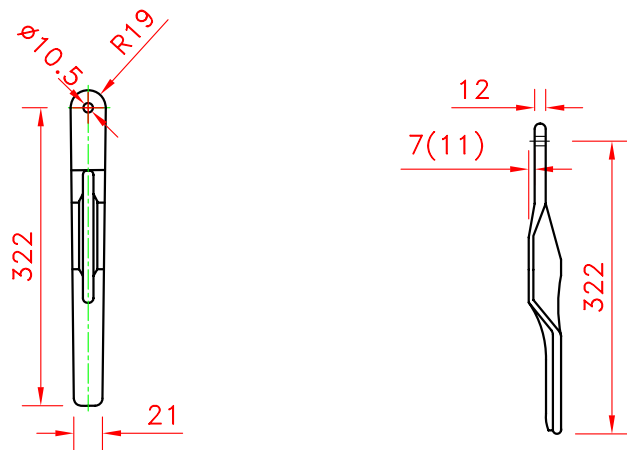

TITLE	Handle	WEIGHT	0.87/0.98/0.87 KGS	
MODEL		MATERIAL	20Mn	
PART NO.	L&R-D23-07A/B/C	UNIT	mm	PAGE NO. 34



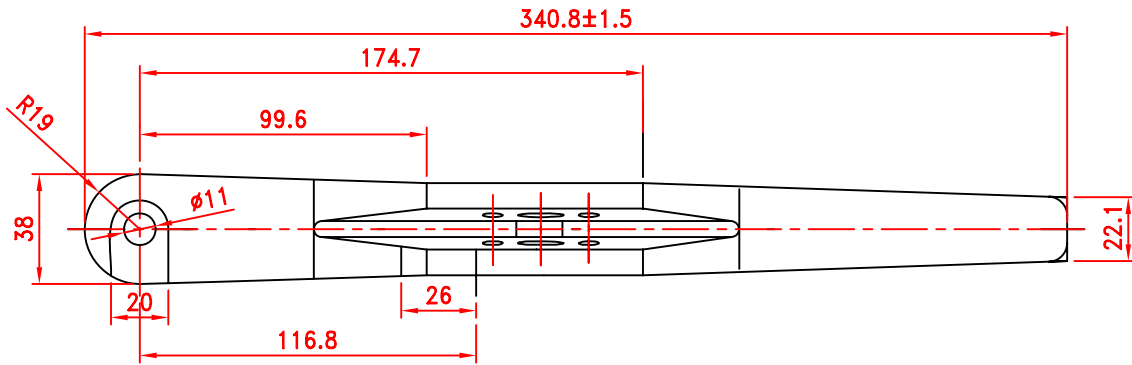
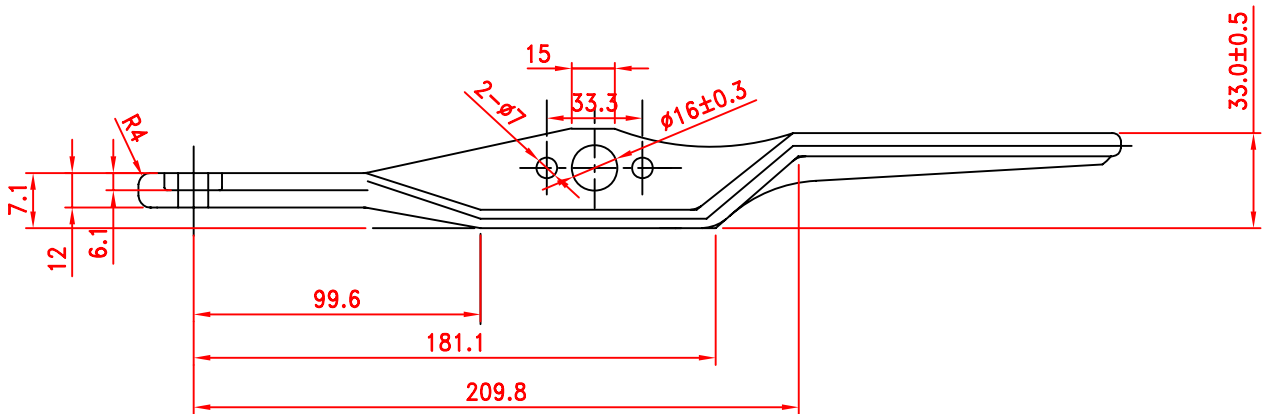

TITLE	Handle ET	WEIGHT	0.84KGS	
MODEL	BE2566M	MATERIAL	20Mn	
PART NO.	L&R-D23-07E	UNIT	mm	PAGE NO. 35



L&R-D23-08A

Forging Type

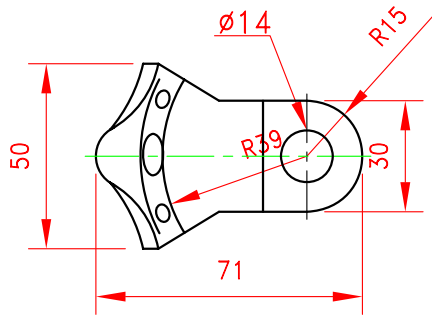
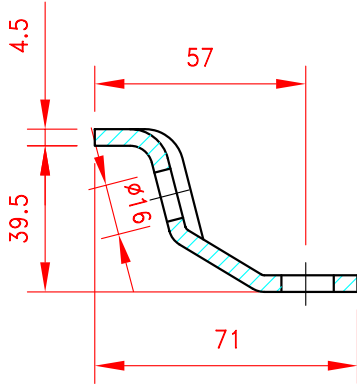

L&R-D23-08B

Press Type

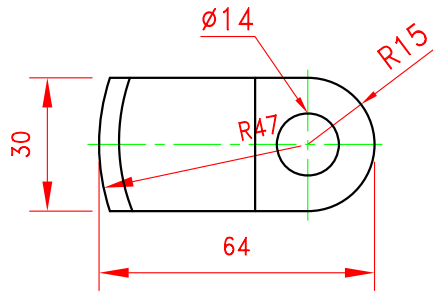
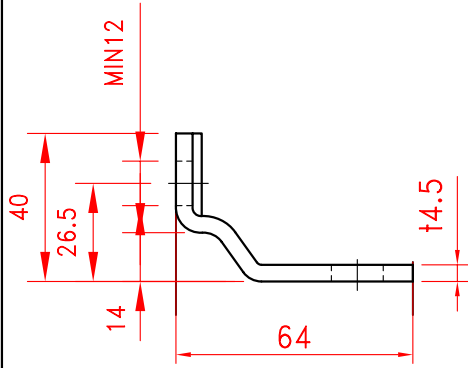

L&R-D23-08C

Forging Type (Without Hole)

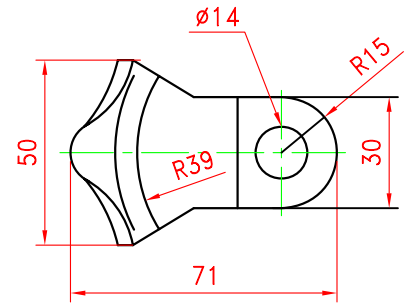
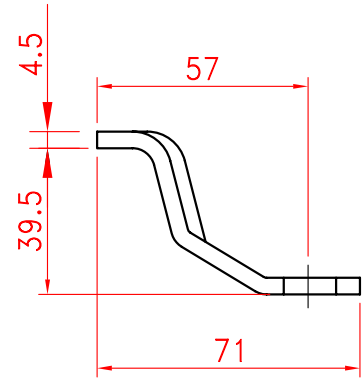

TITLE	Retainer Catch	WEIGHT	0.09/0.08/0.01KGS	
MODEL	BE2566M	MATERIAL	SS400	
PART NO.	L&R-D23-08A/B/C	UNIT	mm	PAGE NO. 36

L&R-D23-09A

Forging Type

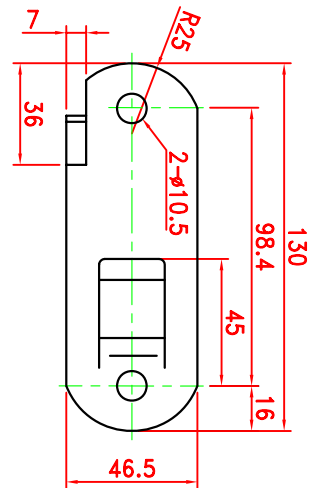
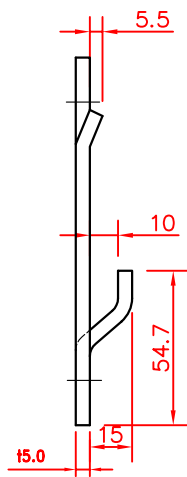

L&R-D23-09B

Press Type

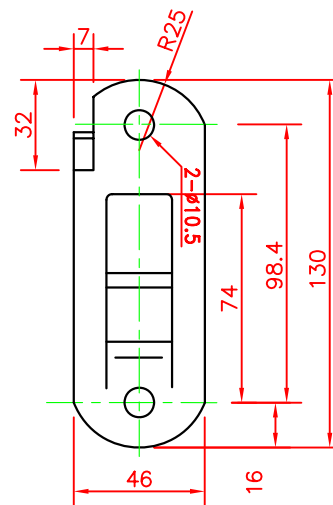
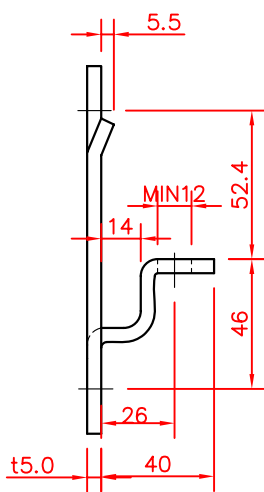

L&R-D23-09C

Forging Type

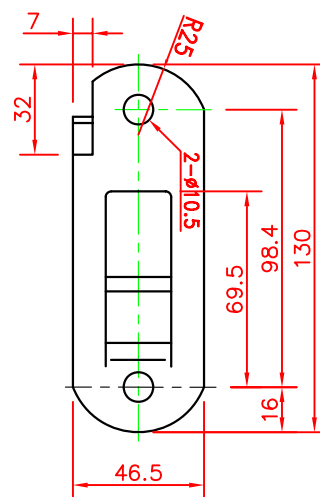
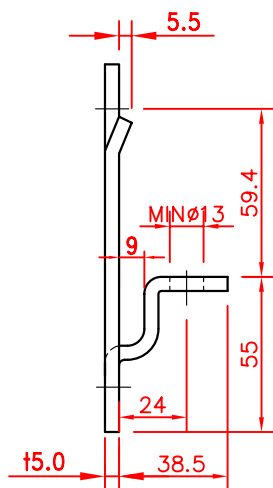

TITLE	Retainer Plate	WEIGHT	0.020/0.196/0.196KGS	
MODEL	BE2566M	MATERIAL	SS400	
PART NO.	L&R-D23-09A/B/C	UNIT	mm	PAGE NO. 37



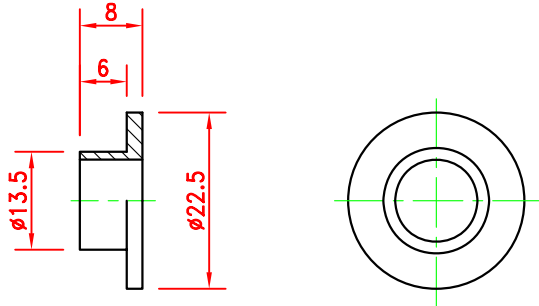

L&R-D23-10 Bush

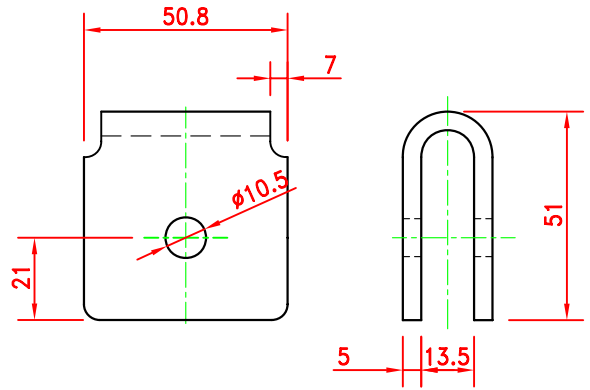

L&R-D23-11 Handle Hub

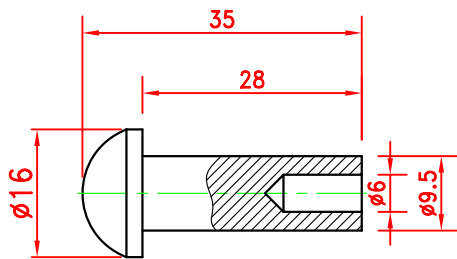

L&R-D23-12 Rivet

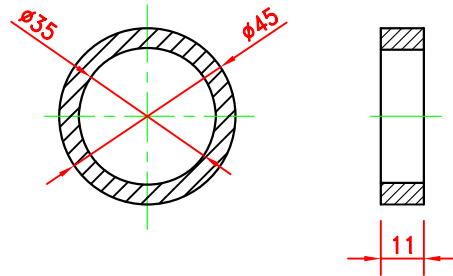

L&R-D23-13 Anti-Rack Ring

TITLE		WEIGHT	KGS
MODEL	BE2566M	MATERIAL	
PART NO.	L&R-D23-10/11/12/13	UNIT	mm
		PAGE NO.	38

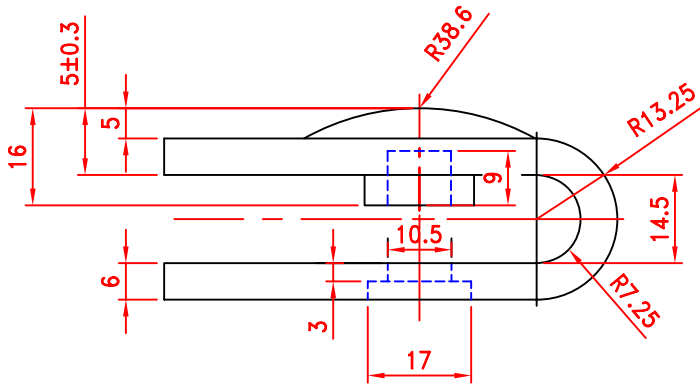
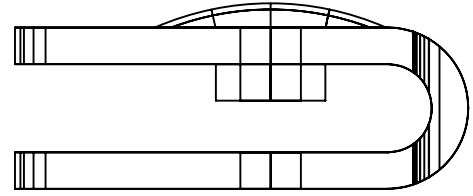
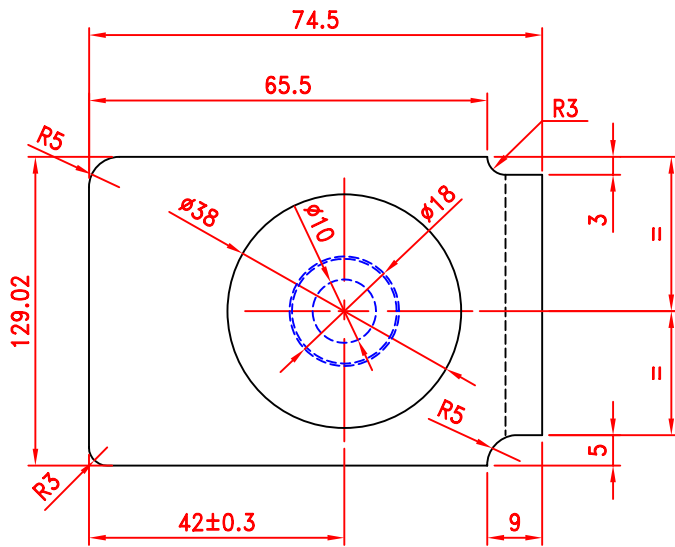

PART NO.	SPEC
L&R-D23-11E	Handle hub ET

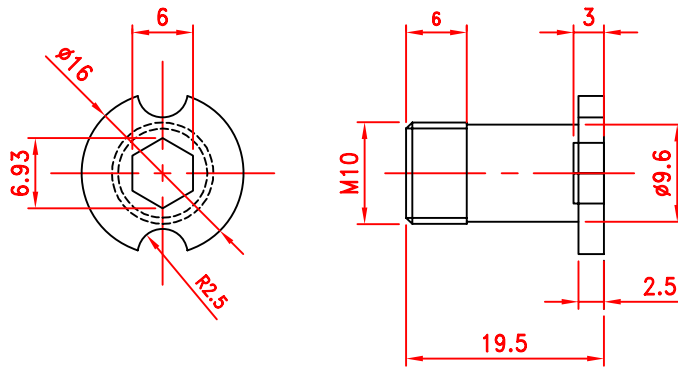

PART NO.	SPEC
L&R-D23-12E	Rivet ET

TITLE	ET	WEIGHT			
MODEL	BE2566M	MATERIAL			
PART NO.	L&R-D23-11E/12E	UNIT	mm	PAGE NO.	39

Upper Short Split Bush

L&R-D23-14

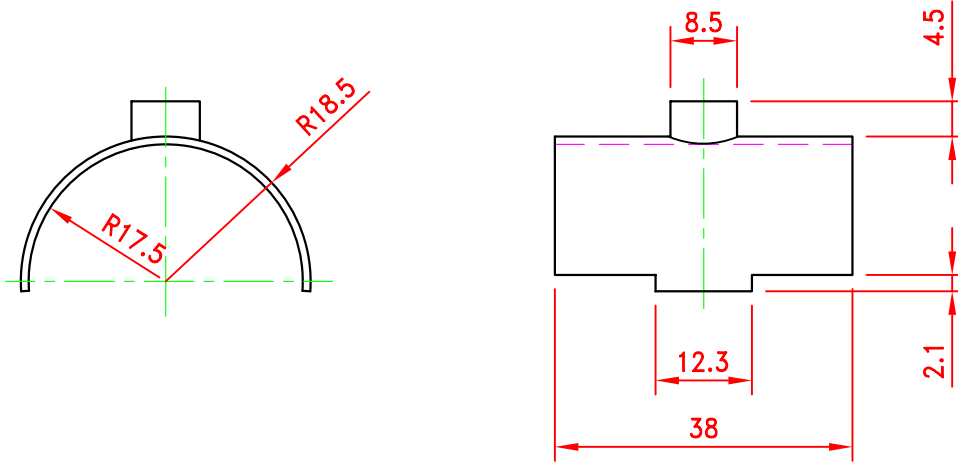

Lower Short Split Bush

L&R-D23-15

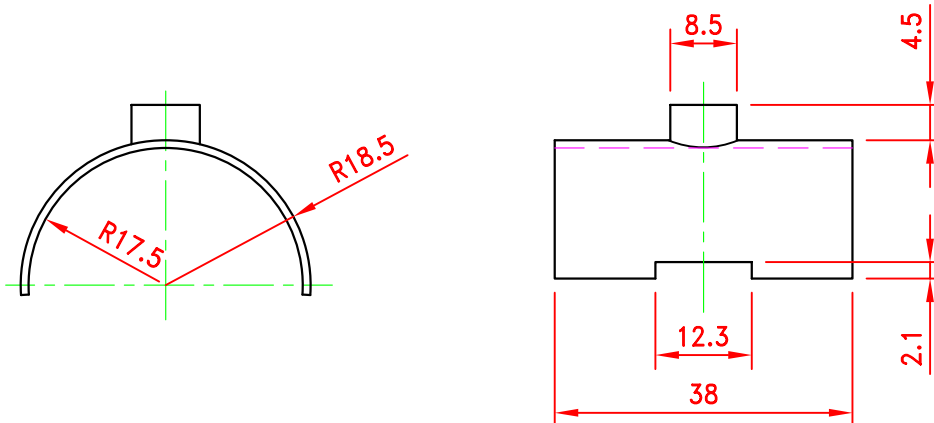

TITLE	Short Split Bush	WEIGHT	0.001/0.001KGS	
MODEL	BE2566M	MATERIAL	ABS	
PART NO.	L&R-D23-14/15	UNIT	mm	PAGE NO. 40

Split Large Bush

L&R-D23-16

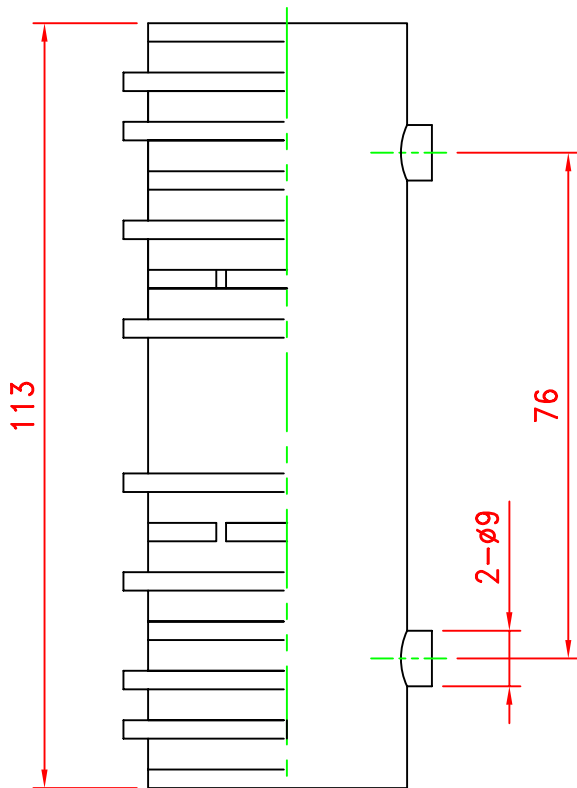

Split Small Bush

L&R-D23-17

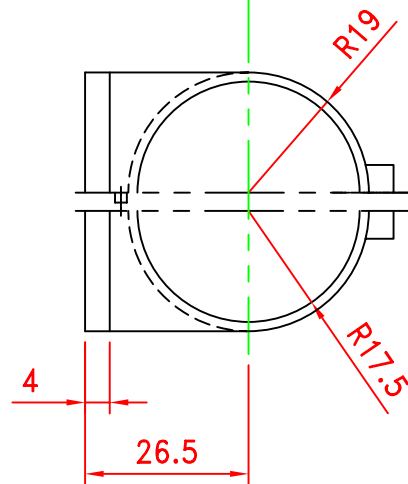
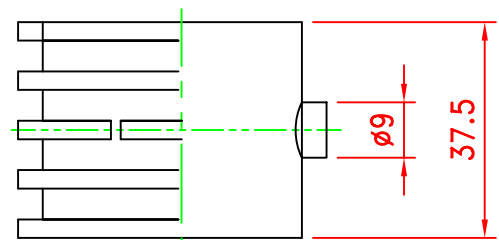

TITLE	Split Bush	WEIGHT	0.010/0.005KGS	
MODEL	BE2566M	MATERIAL	ABS	
PART NO.	L&R-D23-16/17	UNIT	mm	PAGE NO. 41

L&R-D24-01 Froging Type

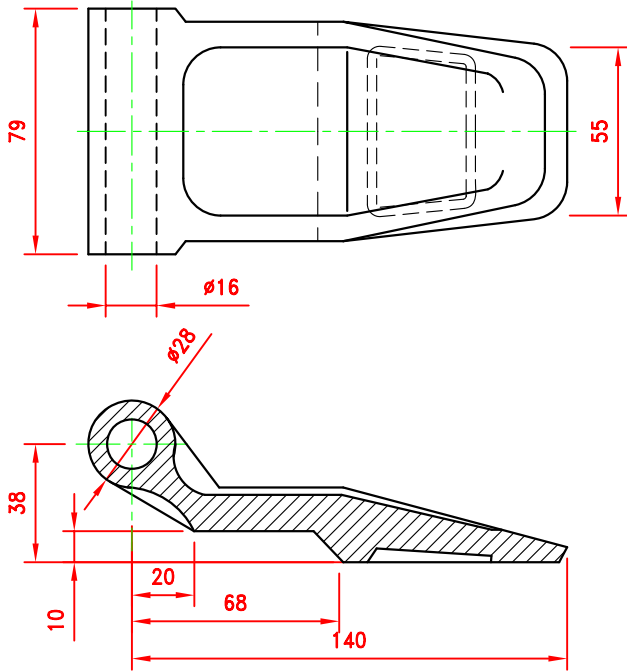

L&R-D24-02 Welding Type

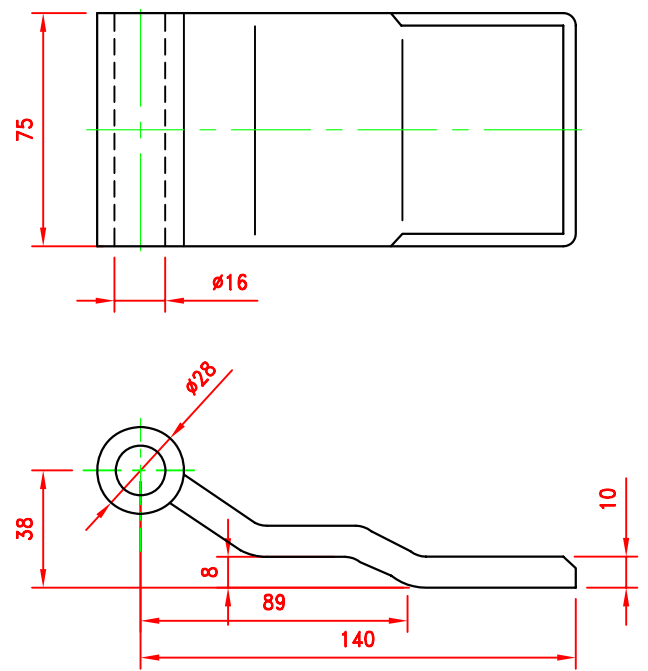

L&R-D24-03 Welding Type

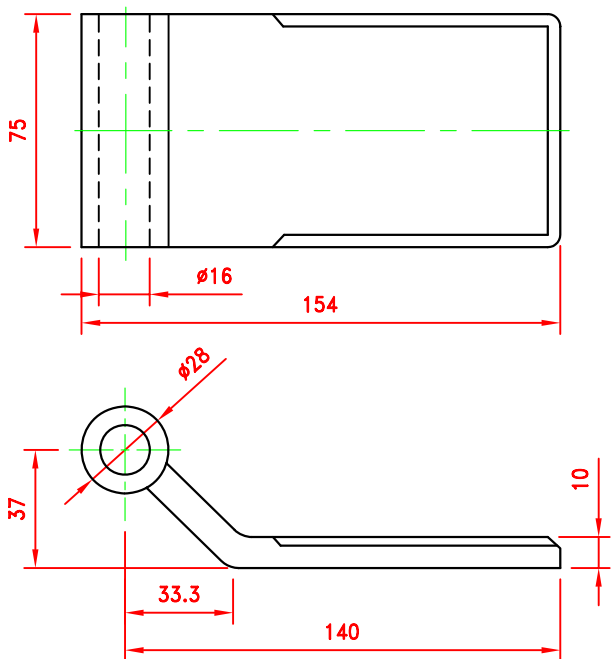

L&R-D24-04 Maersk Type

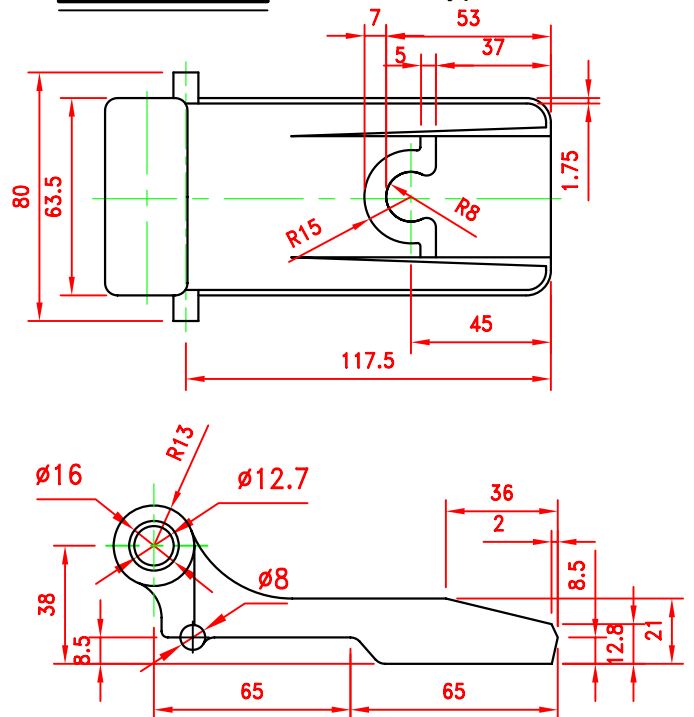

TITLE	Hinge Blade	WEIGHT	1.450/1.010/0.990/1.000KGS	
MODEL		MATERIAL	SC25	
PART NO.	L&R-D24-01/02/03/04	UNIT	mm	PAGE NO. 42

L&R-D24-05

Hinge Pin

SUS304

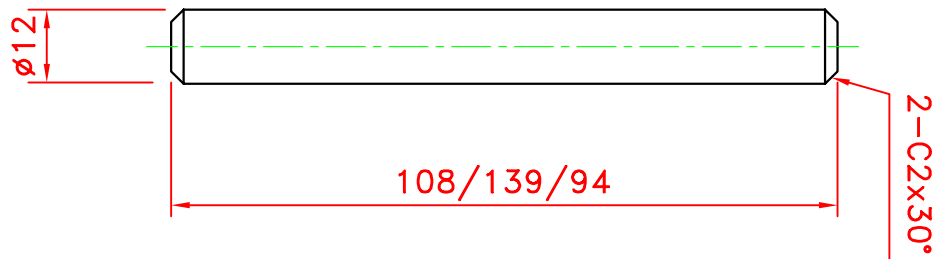

L&R-D24-06

Hinge Lug

SS400

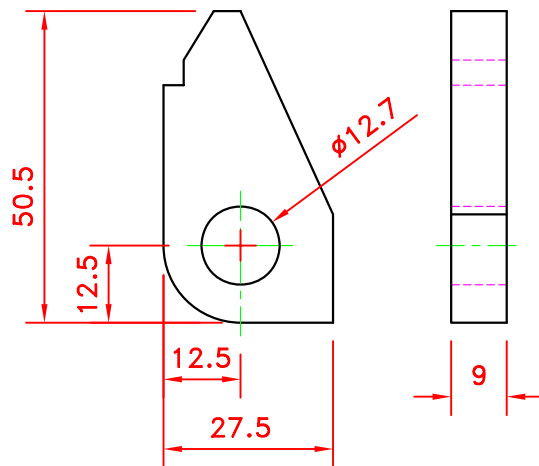

L&R-D24-07

Brass Wash

Brass

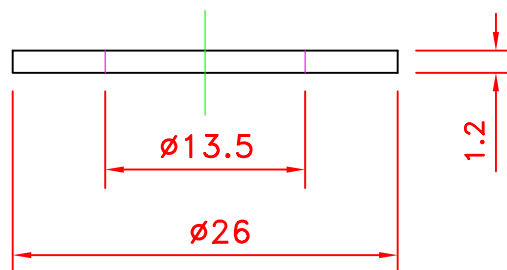

TITLE	Hinge Accessary	WEIGHT	0.100/0.200/ 0.020KGS	
MODEL		MATERIAL	SUS304/SS400/Brass	
PART NO.	L&R-D24-05/06/07	UNIT	mm	PAGE NO. 43

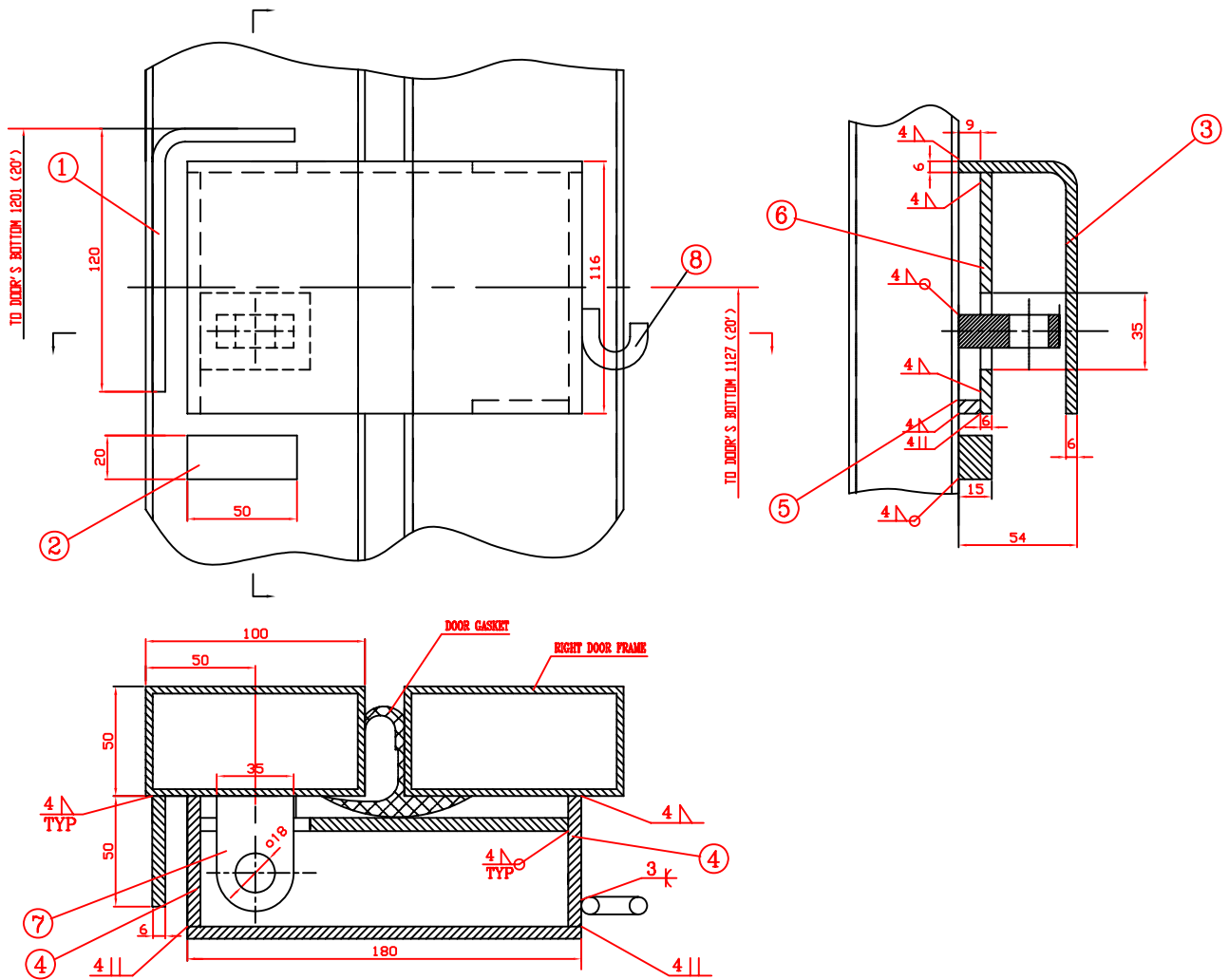

1	Lockbox-8	1
2	Lockbox-7	1
3	Lockbox-6	1
4	Lockbox-5	1
5	Lockbox-4	2
6	Lockbox-3	1
7	Lockbox-2	1
8	Lockbox-1	1
REF NO.	DRG.NO.	PCS

TITLE	Lock box	WEIGHT	3.00KGS	
MODEL		MATERIAL	CORTEN	
PART NO.	L&R-D24-10	UNIT	mm	PAGE NO. 44

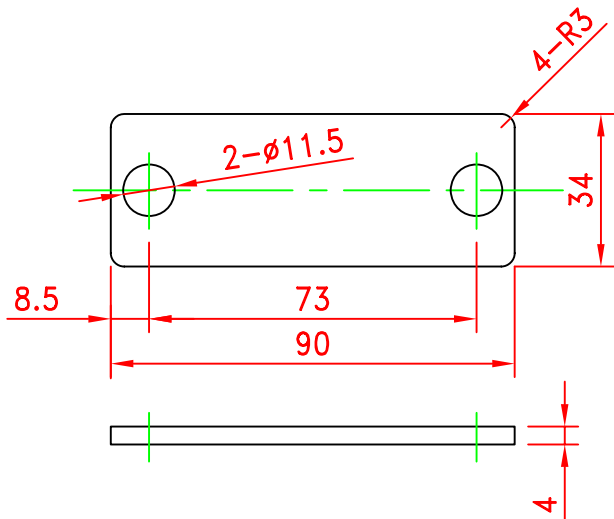

Small Bracket Gasket
L&R-DGE07040 (4MM)

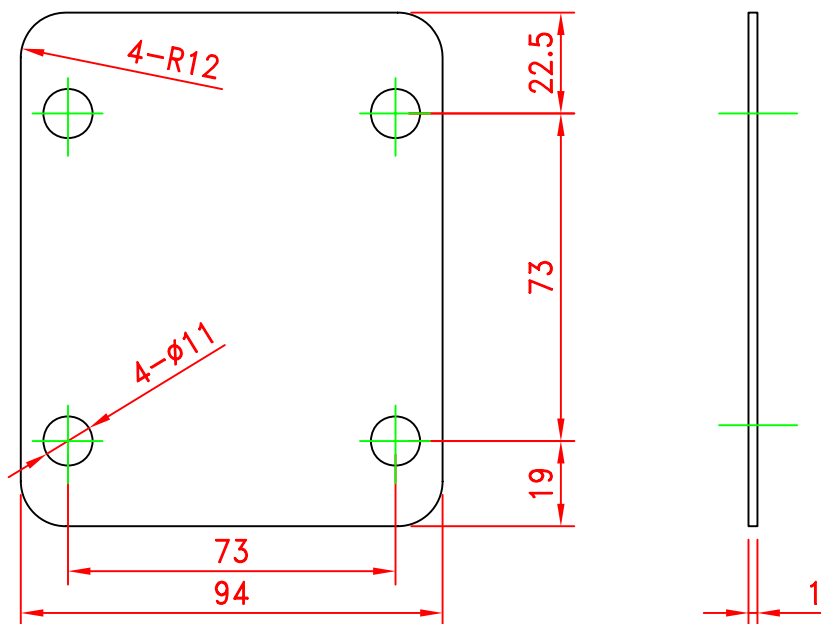

Large Bracket Gasket
L&R-DGE06

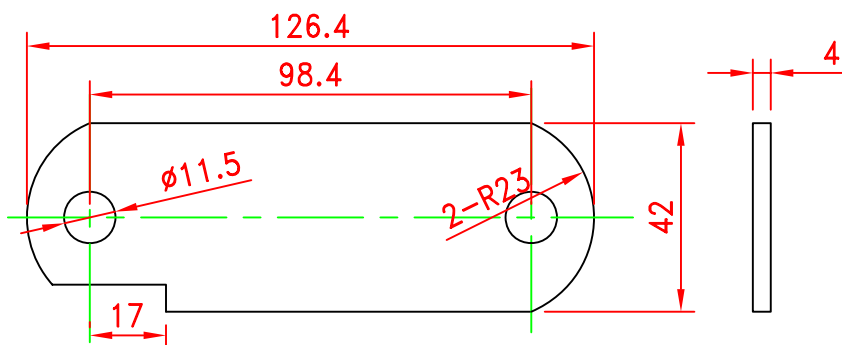

Retainer Bracket Gasket
L&R-DGE08040 (4MM)

TITLE	Bracket Gasket	WEIGHT	0.020KGS	
MODEL		MATERIAL	E.P.D.M	
PART NO.	L&R-DGE	UNIT	mm	PAGE NO. 45



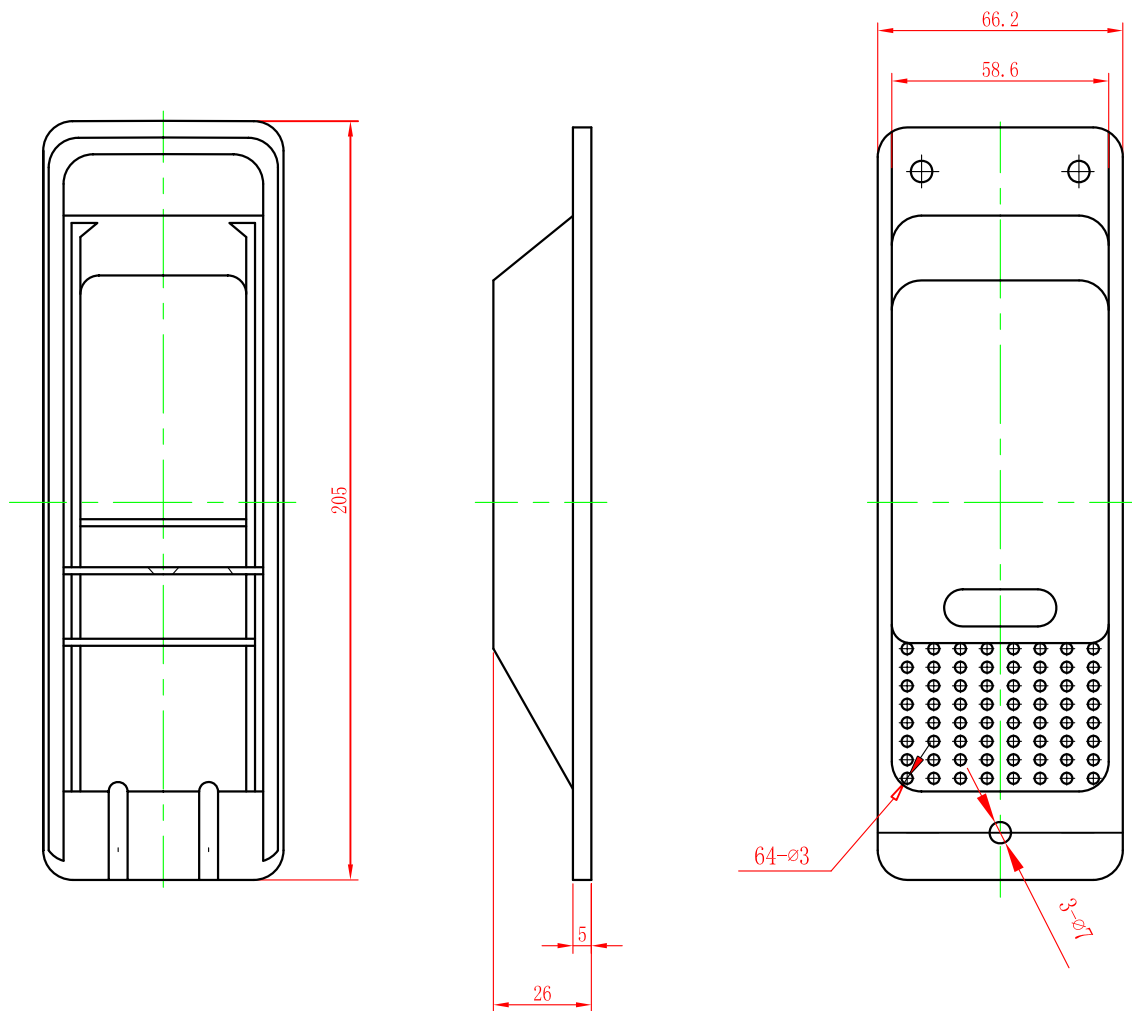

TITLE	Ventilator	WEIGHT	0.070KGS	
MODEL	"S" Type	MATERIAL	ABS	
PART NO.	L&R-D25-01	UNIT	mm	PAGE NO. 46



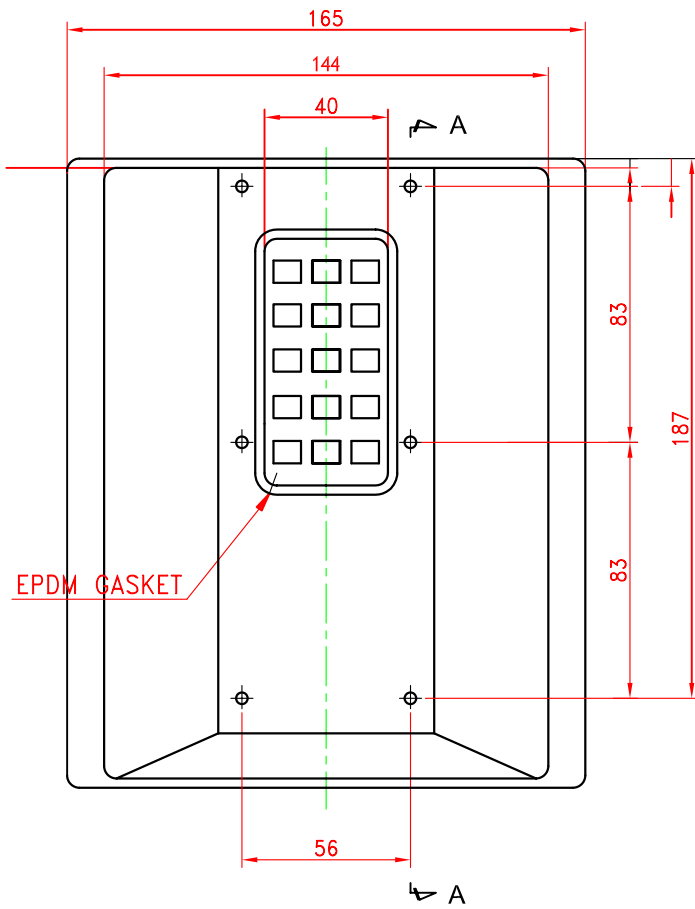

EPDM GASKET

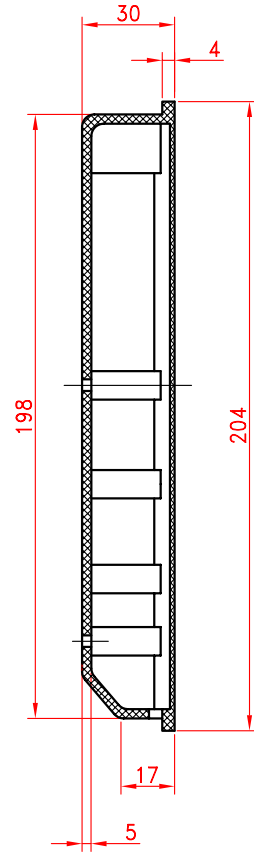

SECTION A-A

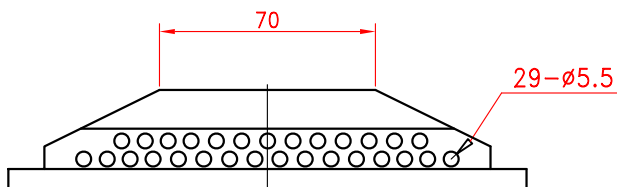

TITLE	Ventilator	WEIGHT	0.300KGS
MODEL	"M" Type	MATERIAL	ABS
PART NO.	L&R-D25-02	UNIT	mm
		PAGE NO.	47



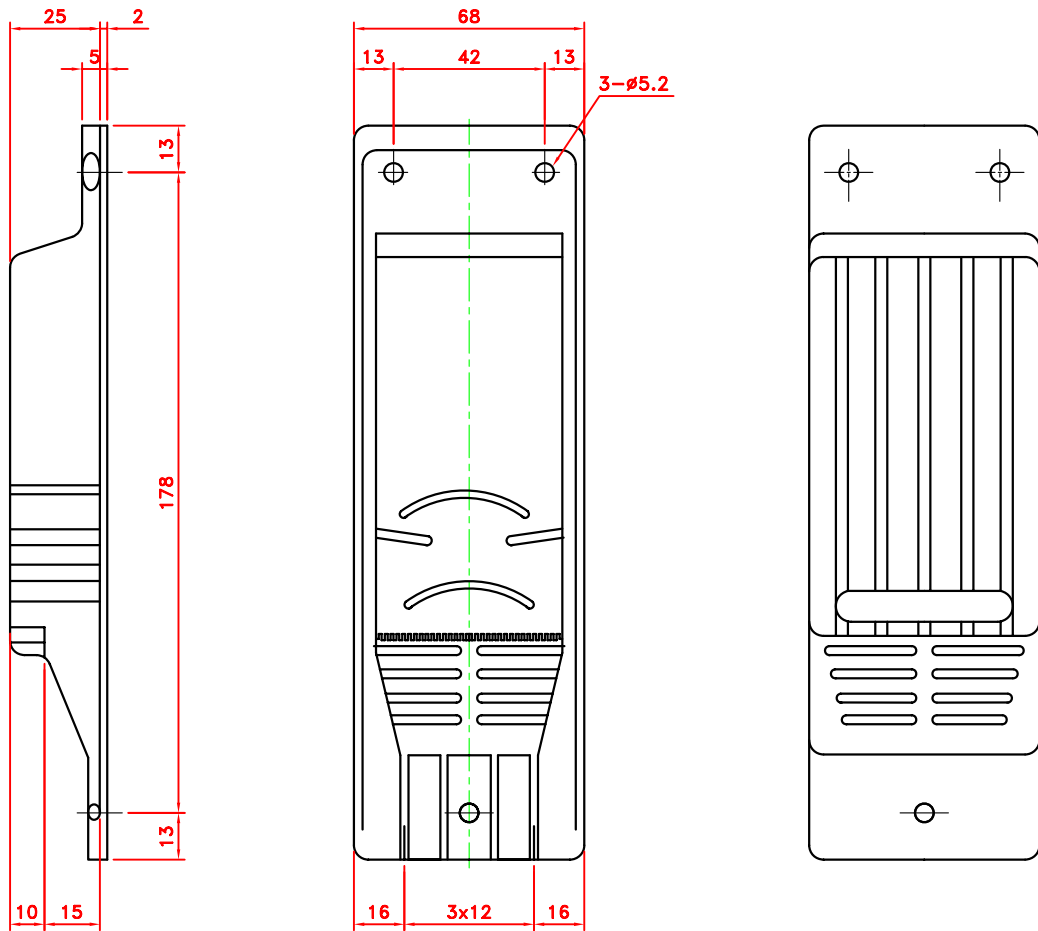

TITLE	Ventilator	WEIGHT	0.070KGS	
MODEL	"TAL" Type	MATERIAL	ABS	
PART NO.	L&R-D25-03	UNIT	mm	PAGE NO. 48



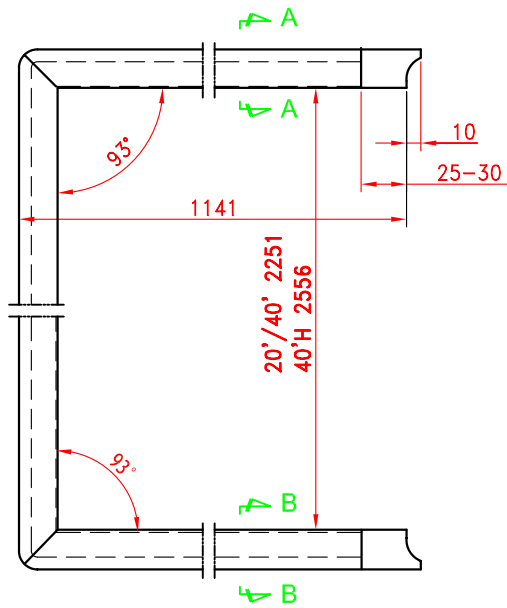

LEFT HAND DOOR ONLY

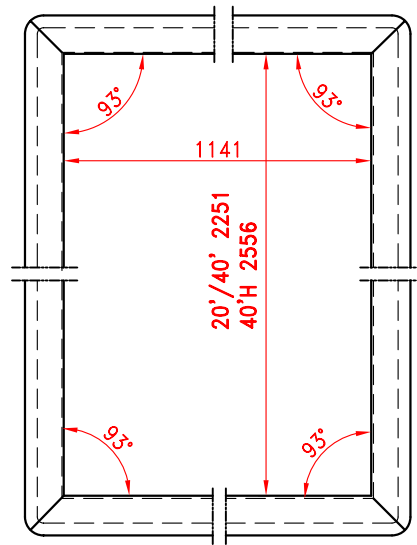

RIGHT HAND DOOR ONLY

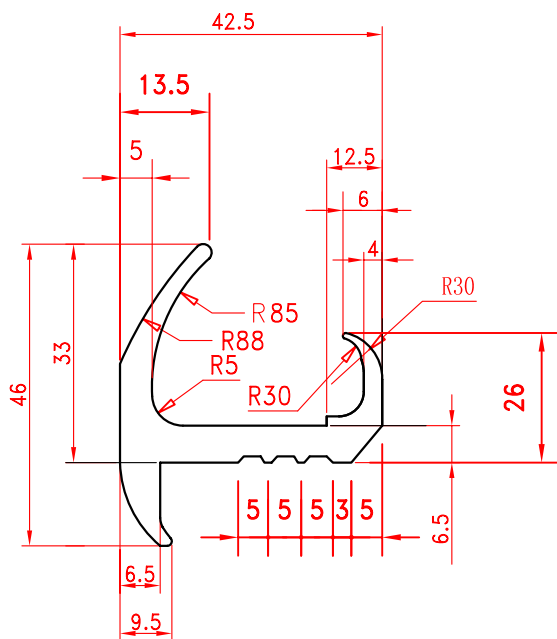

(FOR UPPER&SIDE)

SECTION A-A

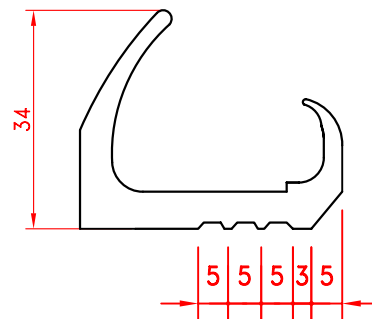

(FOR LOWER ONLY)

SECTION B-B

PART NO		SPEC	
L&R-D26-01A		CONTAINER SET,20'/40'	
L&R-D26-01B		CONTAINER SET,40HC	
WEIGHT		6.000/8.000KGS	
MATERIAL		EPDM	
PART NO.	L&R-D26-01A/B	UNIT	mm
PAGE NO.		49	

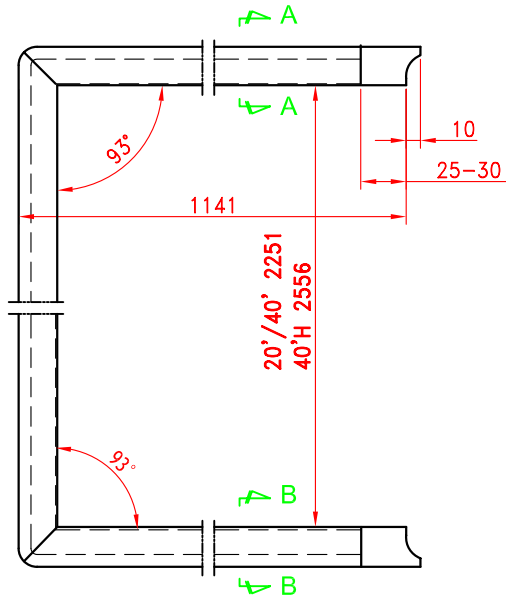

LEFT HAND DOOR ONLY

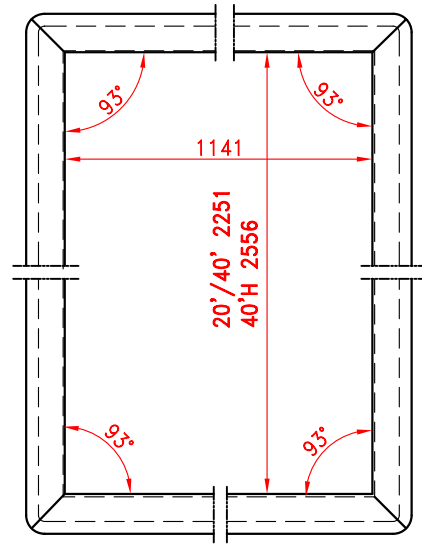

RIGHT HAND DOOR ONLY

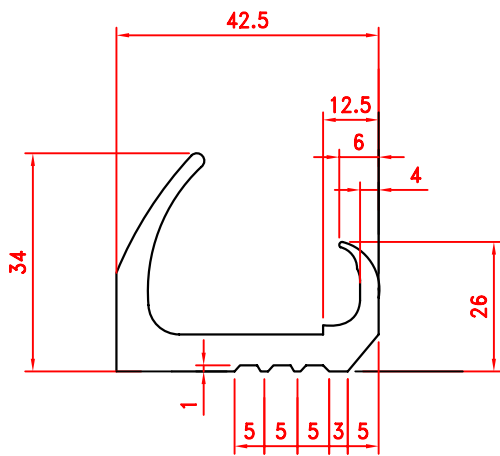

SECTION A-A & B-B

PART NO.	SIZE
L&R-D26-02A	CONTAINER SET, 20'/40'
L&R-D26-02B	CONTAINER SET, 40'H
L&R-D26-02C	2.50MTRS/PC
L&R-D26-02D	40.00MTRS/ROLL
L&R-D26-02E	300mmX300mm

TITLE	Door Seal	WEIGHT	6.000/8.000/1.500/24.000KGS	
MODEL	"C" Type	MATERIAL	EPDM	
PART NO.	L&R-D26-02A/B/C/D/E	UNIT	mm	PAGE NO. 50

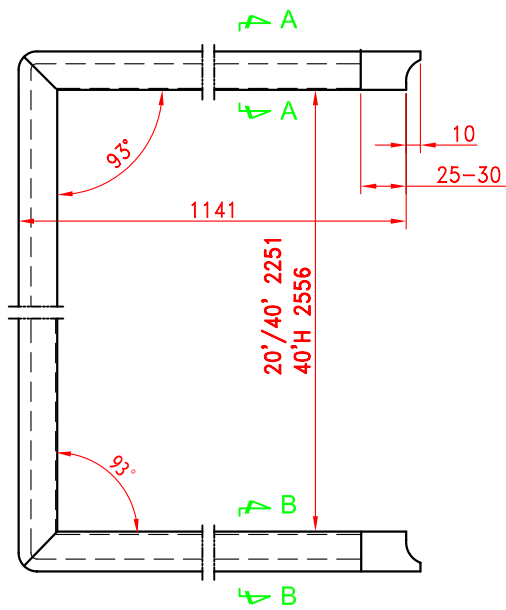

LEFT HAND DOOR ONLY

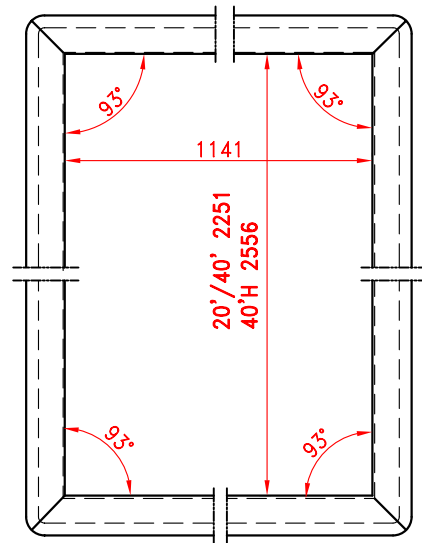

RIGHT HAND DOOR ONLY

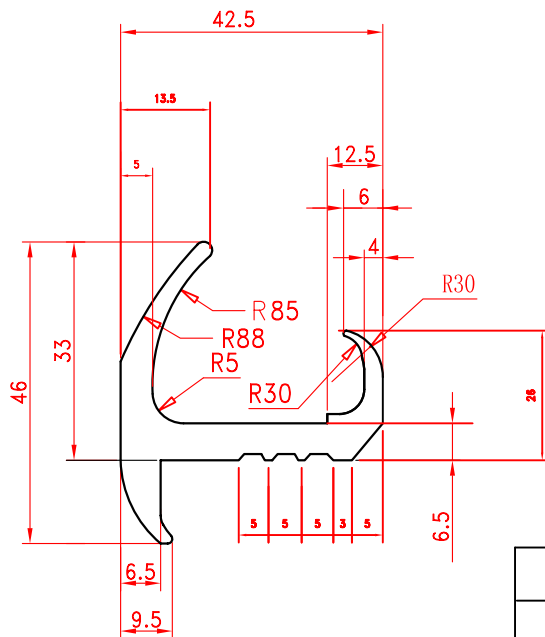

SECTION A-A & B-B

PART NO.	SIZE
L&R-D26-03A	CONTAINER SET, 20'/40'
L&R-D26-03B	CONTAINER SET, 40'H
L&R-D26-03C	2.50MTRS/PC
L&R-D26-03D	300mmX300mm/PC
L&R-D26-03K	1200mmX1200mm/PC

TITLE	Door Seal	WEIGHT	6.000/8.000/1.5000/0.50KGS	
MODEL	"J" Type	MATERIAL	EPDM	
PART NO.	L&R-D26-03A/B/C/D/K	UNIT	mm	PAGE NO. 51

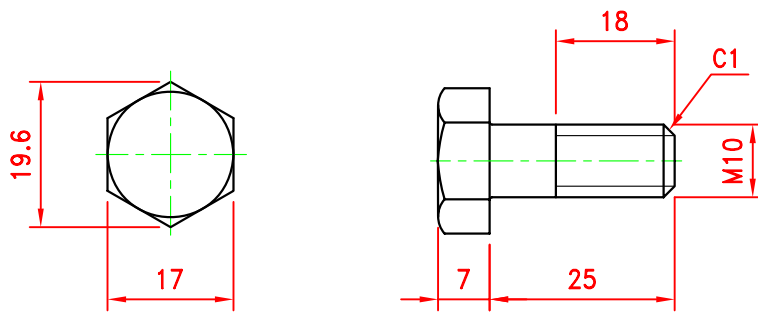

L&R-D27-01

Door Screw

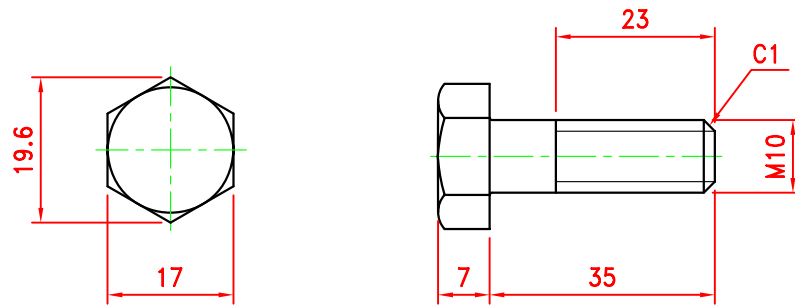

L&R-D27-02

Door Screw

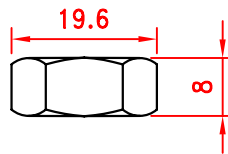

L&R-D27-03

Door Screw Nut

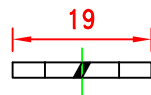

L&R-D27-04

Door Screw Rubber

PART NO.	SPEC
L&R-D27-01	M10X25
L&R-D27-02	M10X35
L&R-D27-03	M10
L&R-D27-04	M10

TITLE	Door Screw	WEIGHT	
MODEL		MATERIAL	EPDM
PART NO.	L&R-D27-01/02/03/04	UNIT	mm
		PAGE NO.	52

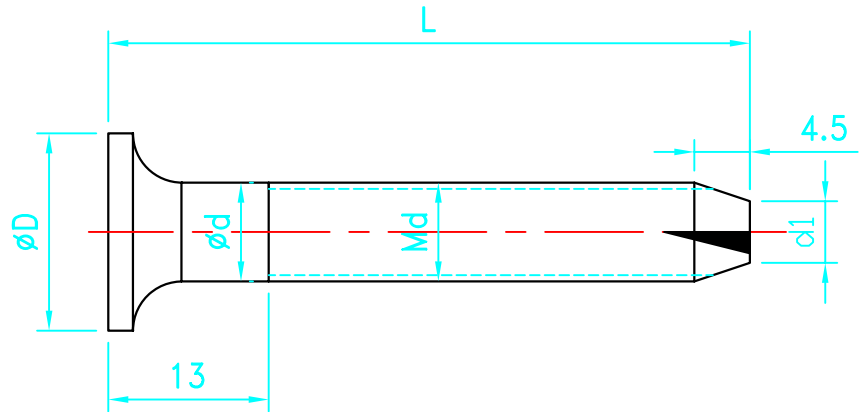
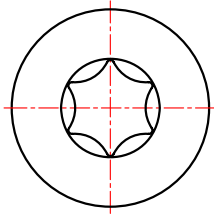
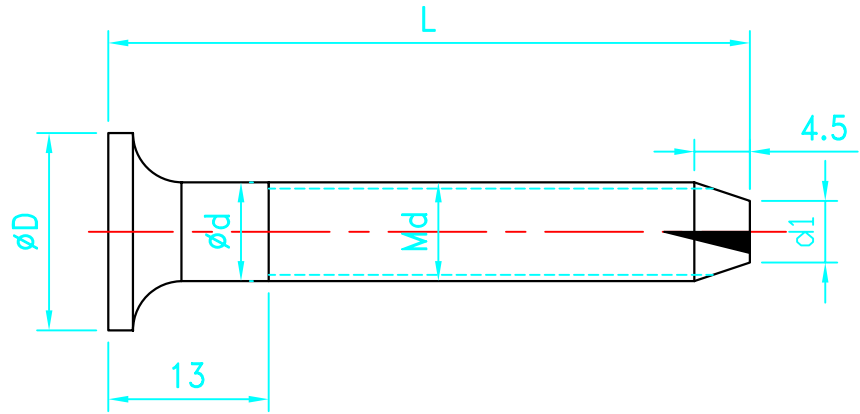
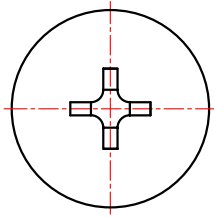

PATR NO.	SPEC	L(mm)	D	d
L&R-D28-01A	M6X45	45	12	6
L&R-D28-01B	M6X65	65	12	6
L&R-D28-01C	M6X50	50	12	6
L&R-D28-02A	M8X45	45	16	8
L&R-D28-02A-1	M8X45	Club Groove		
L&R-D28-02B	M8X50	50	16	8
L&R-D28-02B-1	M8X50	Club Groove		
L&R-D28-02C	M8X65	65	16	8
L&R-D28-02C-1	M8X65	Club Groove		

TITLE	Tapping Screw	MODEL	
SPEC		MATERIAL	
PART NO.	L&R-D28-01ABC/02ABC	UNIT	mm
		PAGE NO.	53





PART NO.	NAME	SPEC
L&R-D36-01	Tapping Screw Bit	Double End, Cross groove
L&R-D36-01-1	Tapping Screw Bit	Simple End, Cross groove
L&R-D36-01-2	Tapping Screw Bit	Simple End, Club groove
L&R-D36-01-3	Socket	M12.5X12.5
L&R-D36-01-4	Socket	M19X19
L&R-D36-01	Redrill Bit	

TITLE	Tapping Screw Bit	MODEL	
SPEC		MATERIAL	
PART NO.	L&R-D36-01-X/02	UNIT	mm
		PAGE NO.	54

SPEC	H	D1	D	L	PATR NO.
M4.0X8.0	1.5	8.0	4.0	8.0	L&R-D29-01
M4.8X14	1.6	9.5	4.8	14.0	L&R-D29-02
M4.8X16.7	1.6	9.5	4.8	16.7	L&R-D29-03

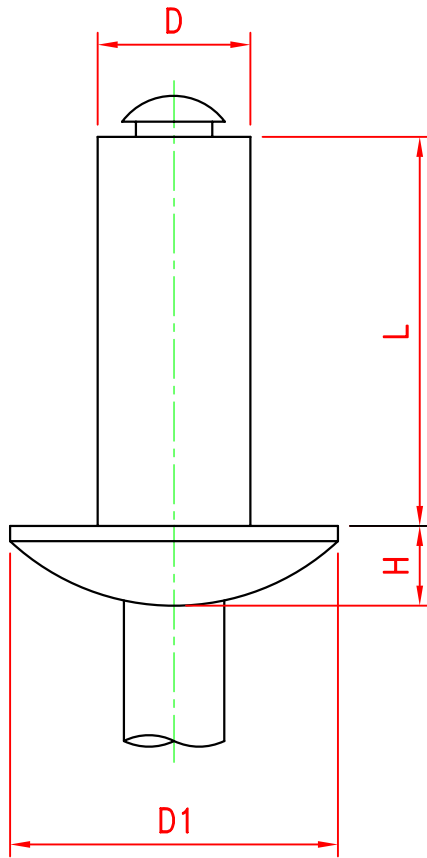

TITLE	Stainless Blind Rivet	MODEL	
SPEC		MATERIAL	Stainless Steel
PART NO.	L&R-D29-01/02/03	UNIT	mm
		PAGE NO.	55

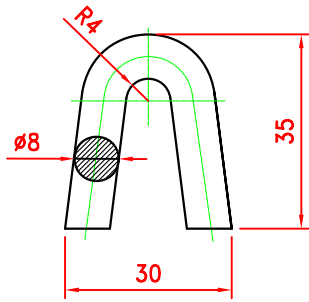

L&R-D30-01

For Door

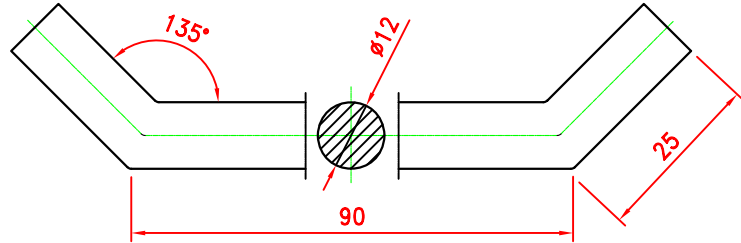

L&R-D30-02

For Front Corner Post

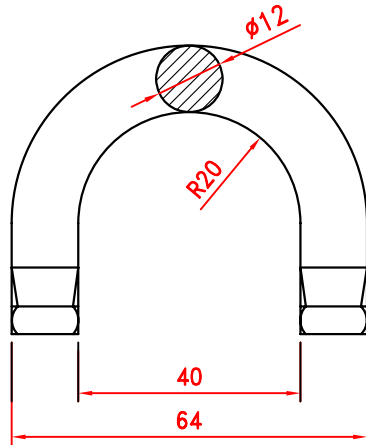

L&R-D30-03

For Top and Bottom Side Rail

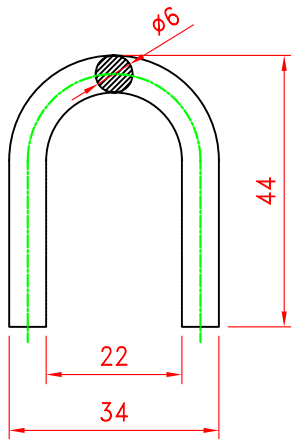
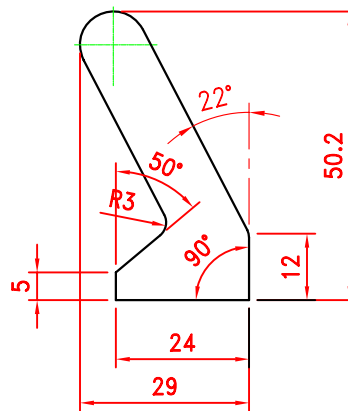

L&R-D30-06

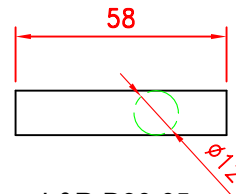

L&R-D30-05

For Rear Corner Post
Lashing Bar

PART NO.	SPEC
	Ø8X70
	Ø12X140
	Ø12X64
	Ø12X58
	Ø6X44

TITLE	Lashing Ring / Bar	WEIGHT	0.050/0.150KGS	
MODEL		MATERIAL	SS41	
PART NO.	L&R-D30-01/02/03/04/05/06	UNIT	mm	PAGE NO. 56

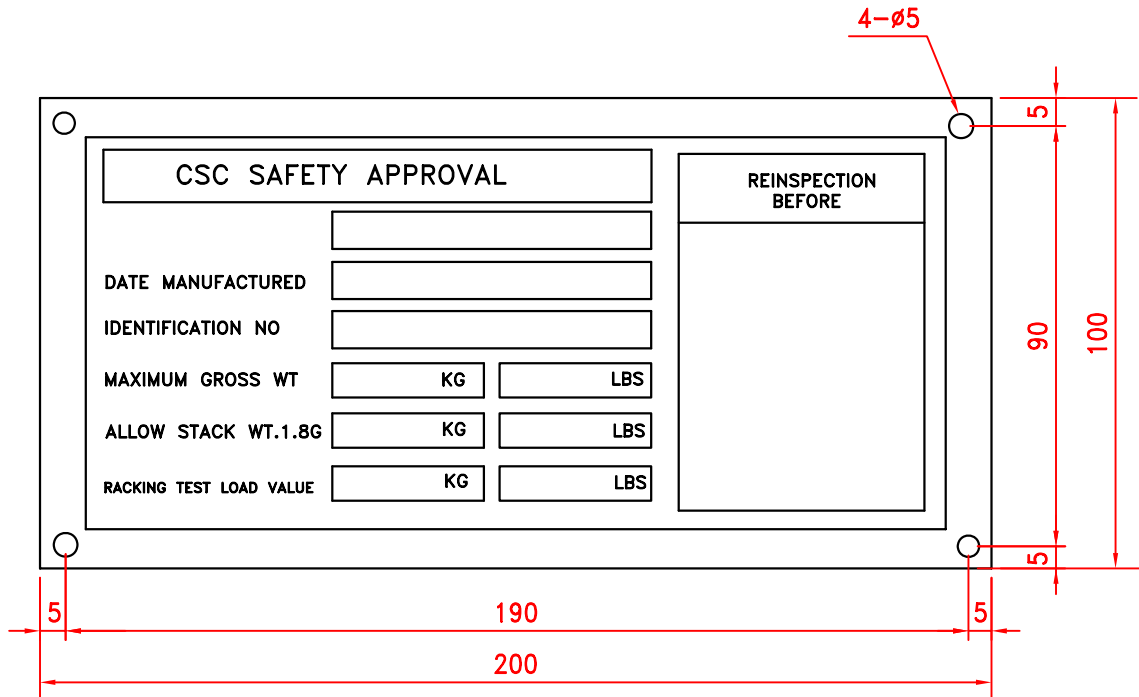

TITLE	CSC Plate	WEIGHT	0.130KGS	
SPEC	0.8X100X200	MATERIAL	Stainless Steel	
PART NO.	L&R-D31-01	UNIT	mm	PAGE NO. 57



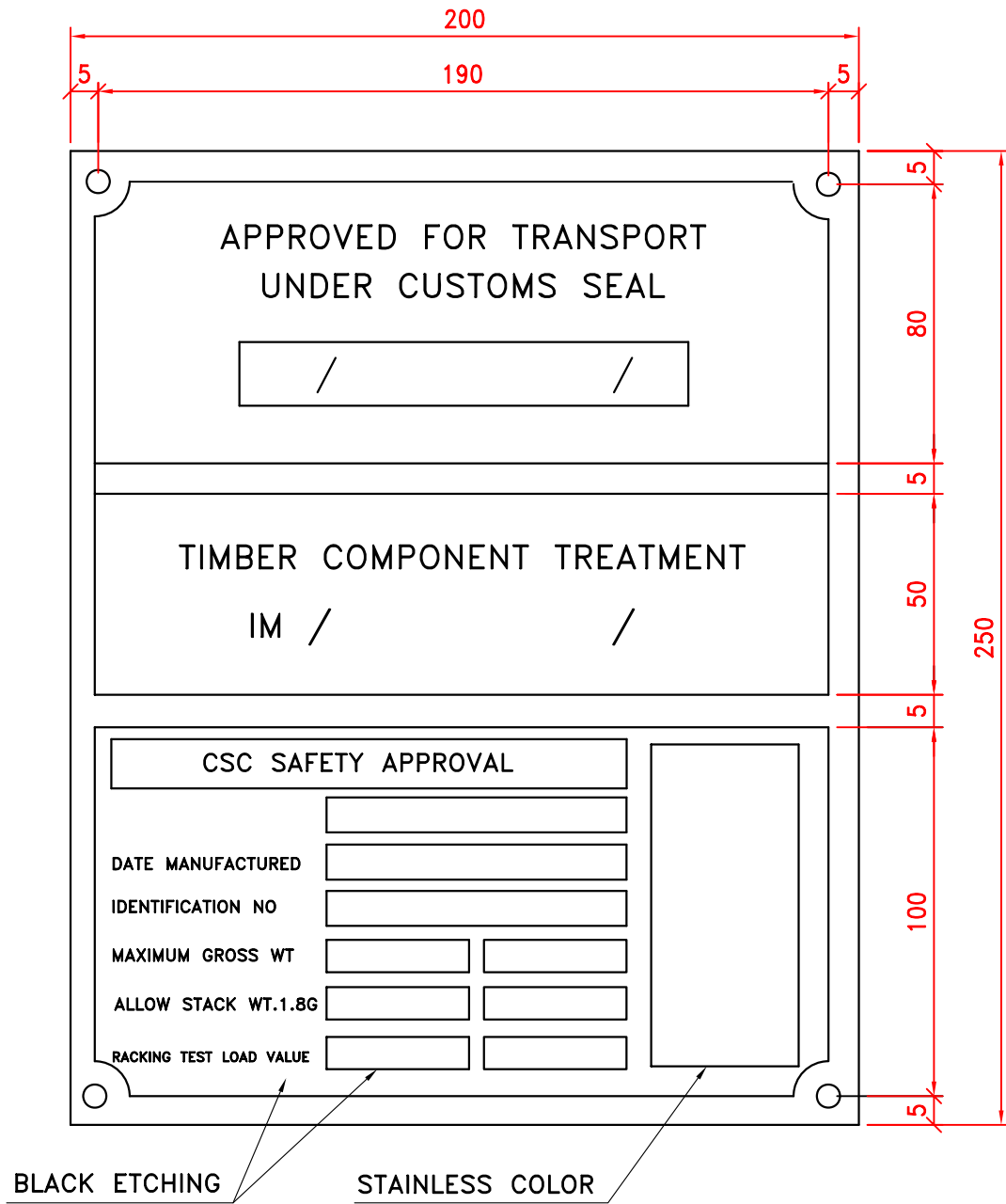

TITLE	CSC Plate	WEIGHT	0.320KGS	
SPEC	0.8X200X250	MATERIAL	Stainless Steel	
PART NO.	L&R-D31-02	UNIT	mm	PAGE NO. 58

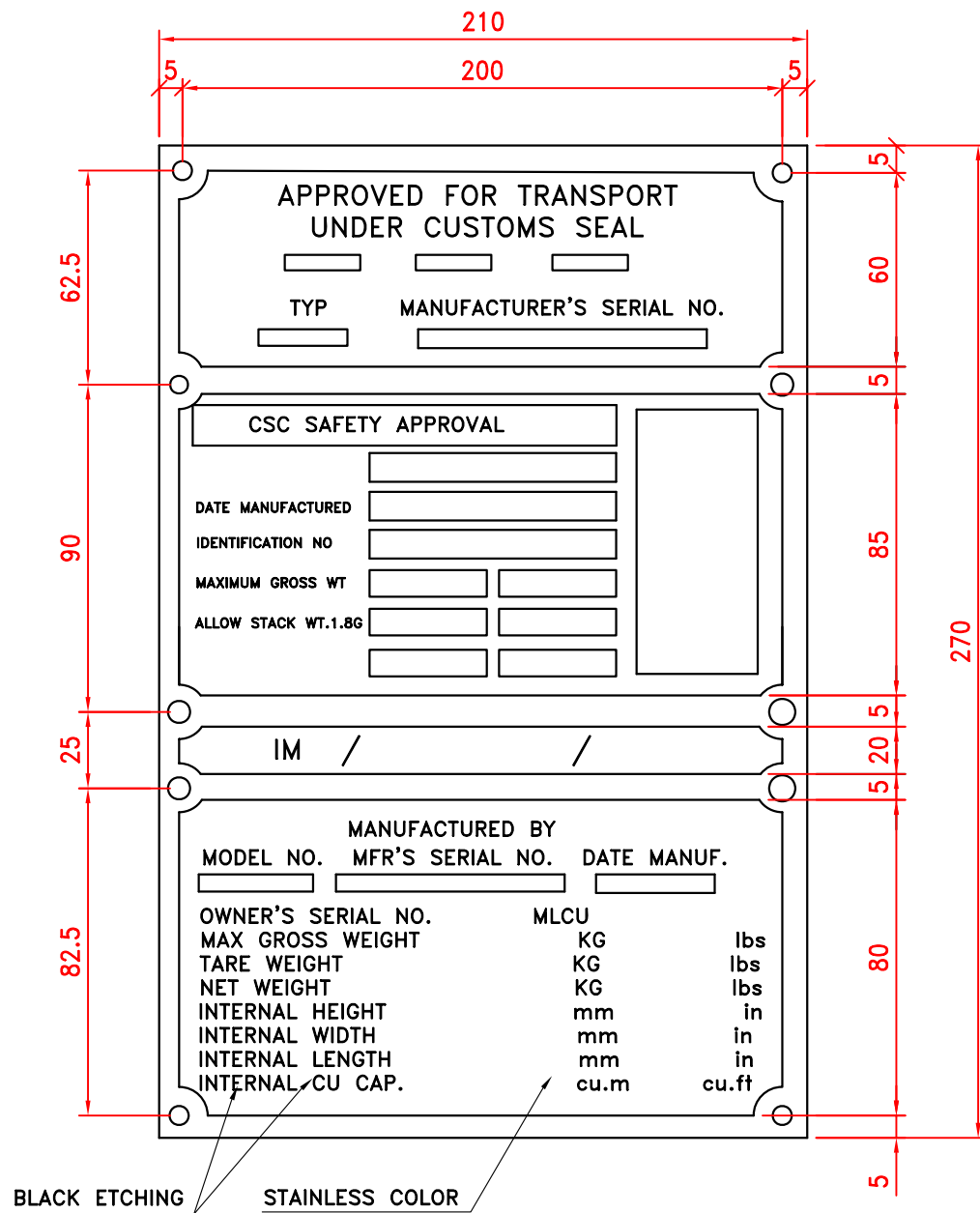

TITLE	CSC Plate	WEIGHT	0.360KGS
SPEC	0.8X210X270	MATERIAL	Stainless Steel
PART NO.	L&R-D31-03	UNIT	mm
		PAGE NO.	59



L&R

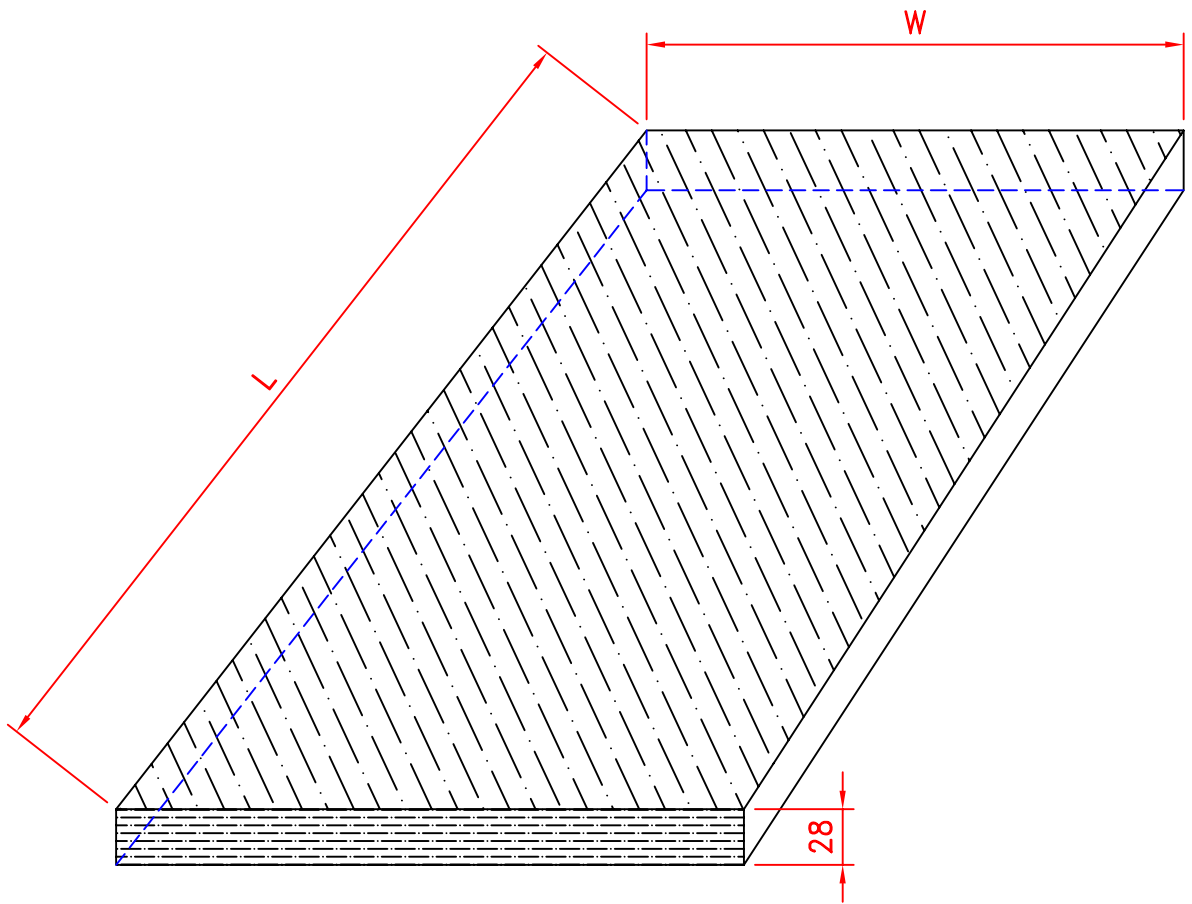

PART NO.	SPEC
L&R-D32-01A	28X1160X2400
L&R-D32-01B	28X640X2400
L&R-D32-01C	28X1220X2440

TITLE	Wooden Flooring	WEIGHT	
SPEC		MATERIAL	
PART NO.	L&R-D32-01A/B/C	UNIT	mm
		PAGE NO.	60



L&R

L&R-D33-01A

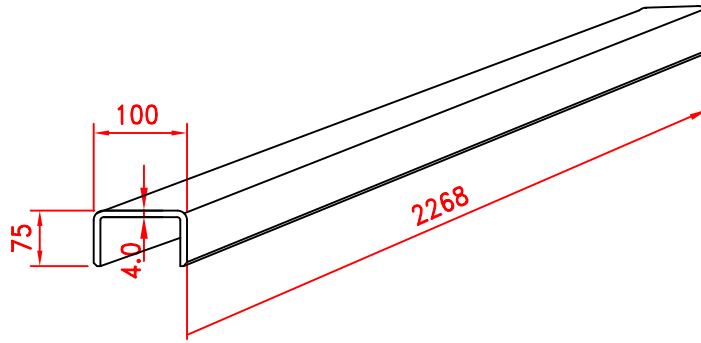

L&R-D33-01B

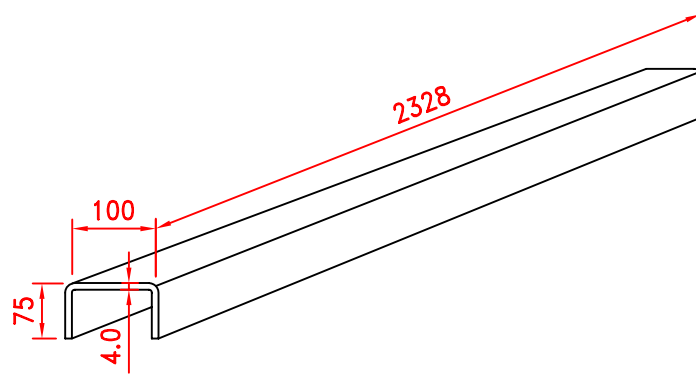

L&R-D33-01C

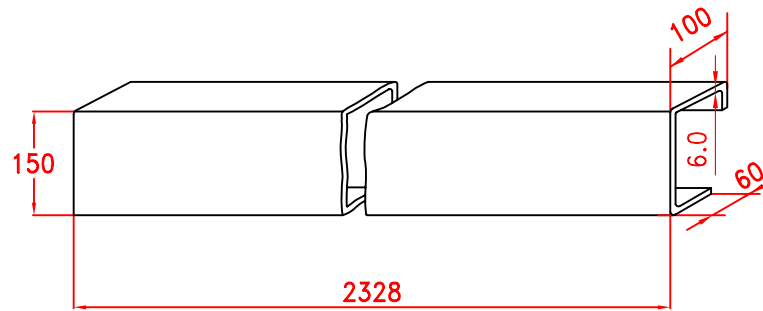

PART NO.	SPEC
L&R-D33-01A	4.0X75X100X75X2268
L&R-D33-01B	4.0X100X2328
L&R-D33-01C	6.0X100X150X60X2328

TITLE	Gooseneck Cross Rail	WEIGHT	16.664/17.105/38.048KGS
SPEC		MATERIAL	CORTEN
PART NO.	L&R-D33-01A/B/C	UNIT	mm
		PAGE NO.	61

Gooseneck Side Rail

L&R-D33-02

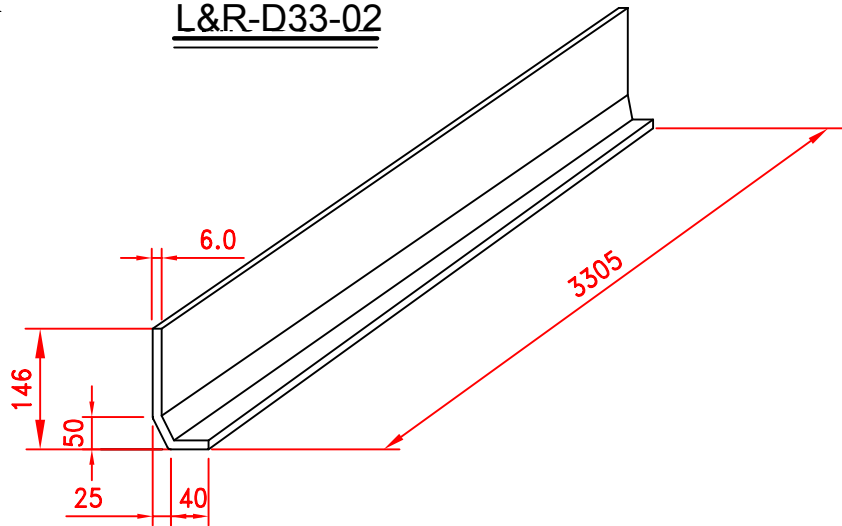

Gooseneck Bottom Rail

L&R-D33-03

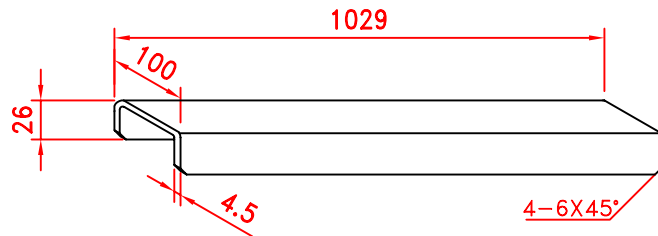

Gooseneck Plate

L&R-D33-04

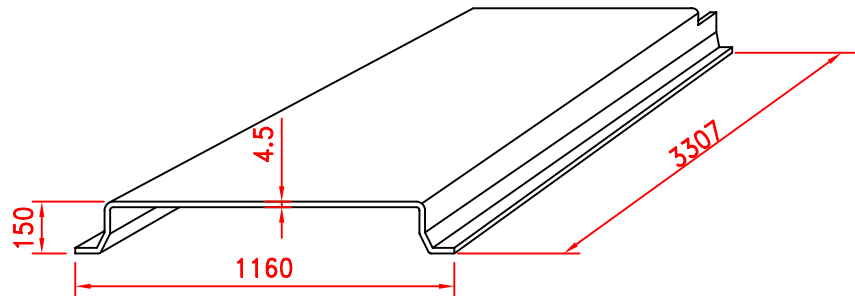

PART NO.	SPEC
L&R-D33-02	6.0X146X65X3305
L&R-D33-03	4.5X26X100X26X1029
L&R-D33-04	4.5X150X1160X150X3307

TITLE	Gooseneck Rail Accessary	WEIGHT	28.487/4.871/161.942KGS
SPEC		MATERIAL	CORTEN
PART NO.	L&R-D33-01A/B/C	UNIT	mm
		PAGE NO.	62

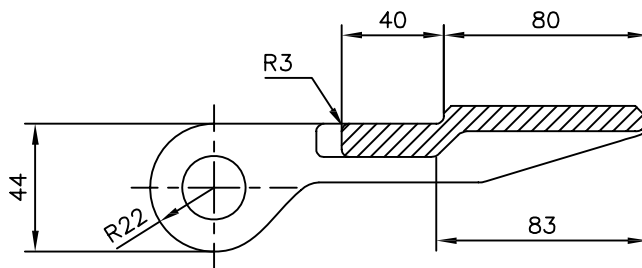
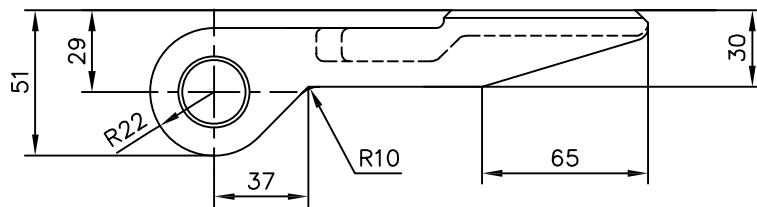
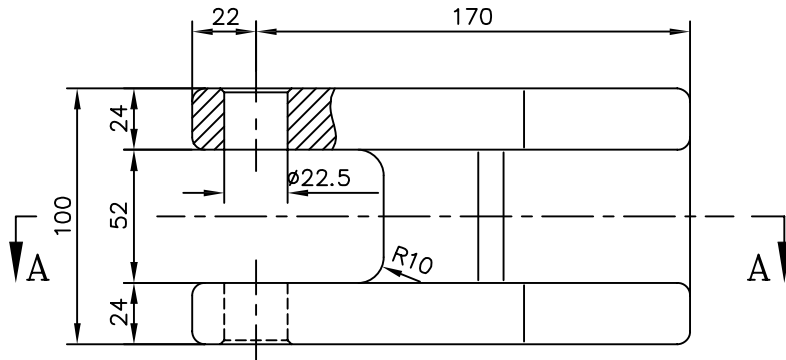

SECTION A-A

TITLE	Hing Blade, Open Top	MODEL	
SPEC		MATERIAL	
PART NO.	L&R-K01-05	UNIT	mm
		PAGE NO.	63

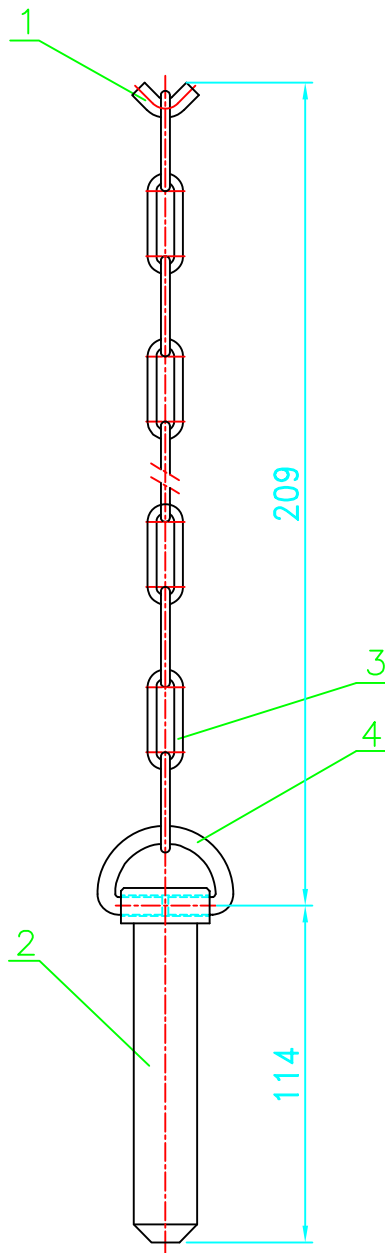

4	CHAIN END RING	R47300-0009-04	1
3	CHAIN	R47300-0009-03	X
2	LOCKING PIN	R47300-0009-02	1
1	STAPLE FOR LOCKING PIN	R47300-0009-01	1
REF. NO.	DESCRIPTION	DRG.NO.	PCS

TITLE	Hinge Pin with Chain	WEIGHT	
MODEL		MATERIAL	SS400
PART NO.	L&R-K01-06	UNIT	mm
		PAGE NO.	64



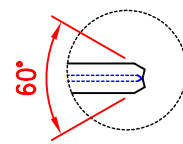
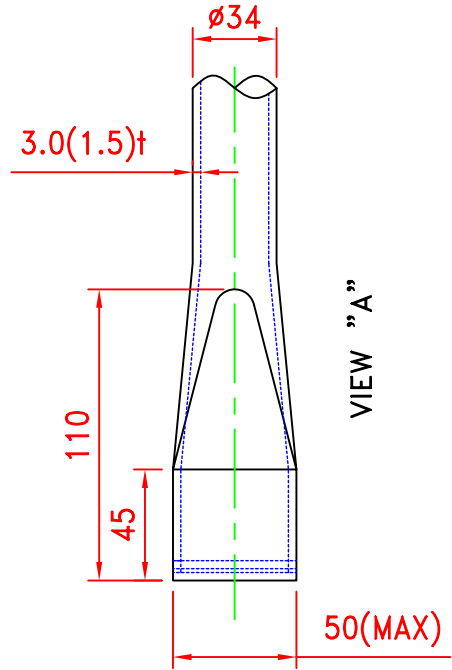
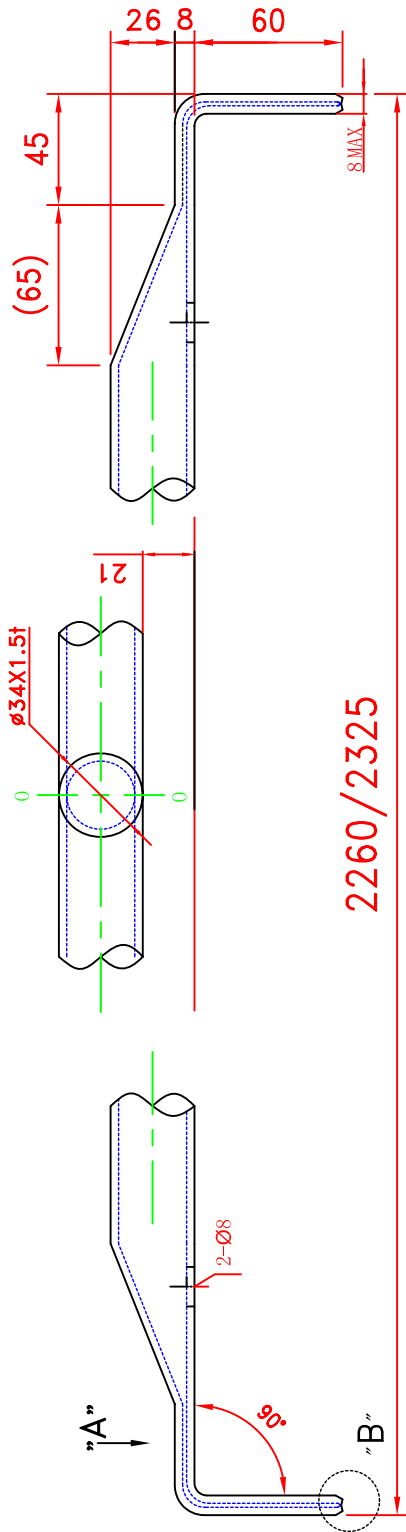

TITLE	Roof Bow	MODEL	5.8KG/6.0KG	
SPEC	L=2260/2325	MATERIAL		
PART NO.	L&R-K03-01/02	UNIT	mm	PAGE NO. 65

